

SERIES 99/97/96 ANSI RANGE

Series 99 Forged Gate Valves are linear motion valves devised for stopping the flow of the service fluid when necessary, not being suitable for regulating purpose. They are of robust and compact design, conventional port, bolted bonnet, outside screw and yoke, rising stem and bidirectional. The atmospheric sealing is achieved by flexible graphite rings. The two vertical slightly sloped seats with solid wedge finely machined favor a tight shut off, being largely used in the power, chemical and oil industry sectors. The range is also comprehensive of a wide offer of different versions and options. The standard operation is achieved by handwheel, and they can also be arranged for automation with different kinds of actuators.

Precise machining of components for optimal performance

Outside screw and yoke rising stem

Back Seat feature

Seat surface can be hardened to increase wear resistance

Solid Wedge

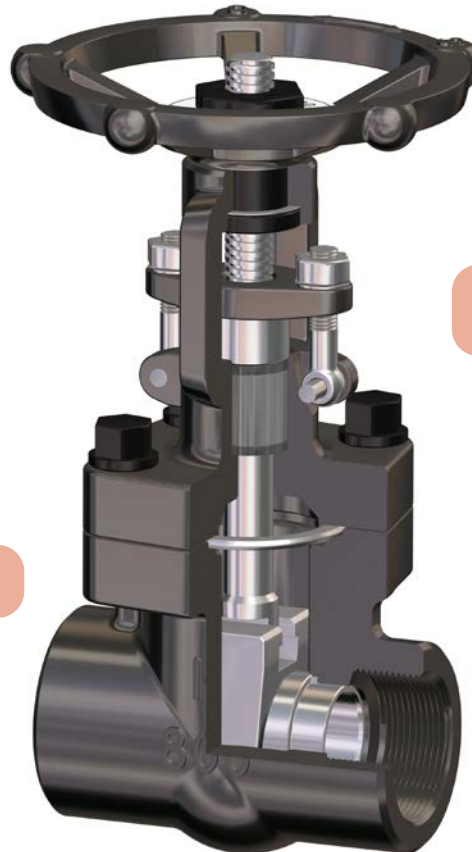

Ergonomic non-rising handwheel

Marking for identification and full traceability purpose

Robust and compact construction

Great versatility in end connections, materials and configurations

Main Features / Reference Standards

Design: API 602
 Pressure Rating: 800/1500/2500#
 Face to face length: Manufacturer standard
 Valve end connections: Threaded NPT to ASME B1.20.1 / BSP to ISO 228-1 / BSPT to ISO 7-1
 Welded SW to ASME B16.11
 Marking: MSS SP-25
 Inspections & Tests: API 598
 Bidirectional design
 Zinc phosphated surface protection for forged steel valves
 Product may compliance with Directive 2014/68/EU on Pressure Equipment (PED) and Machinery Directive 2006/42/EC for European Union territory

Main Duties / Limits of use

Fluids compatible with materials of construction. Questions referring to chemical resistance, please consult us
 Pressure / Temperature Rating to ASME B16.34. See section "Engineering & Performance Data"
 For products compliant with Directive 2014/68/EU, observe also limits acc. to Annex II tables 6 & 8 (gases & liquids group 1*) and tables 7 & 9 (gases & liquids group 2*) up to category III
 *Classification of fluids (group 1 or 2) acc. to Directive 2014/68/EU, Article 13

Options

Diverse body materials and trim combinations, different valve connections, extended bonnet, bellow seal, pressure seal, welded bonnet, different actuation, limit switches... Please consult us

Main Parts and Materials

SERIES 99/97 ANSI RANGE
Class 800&1500

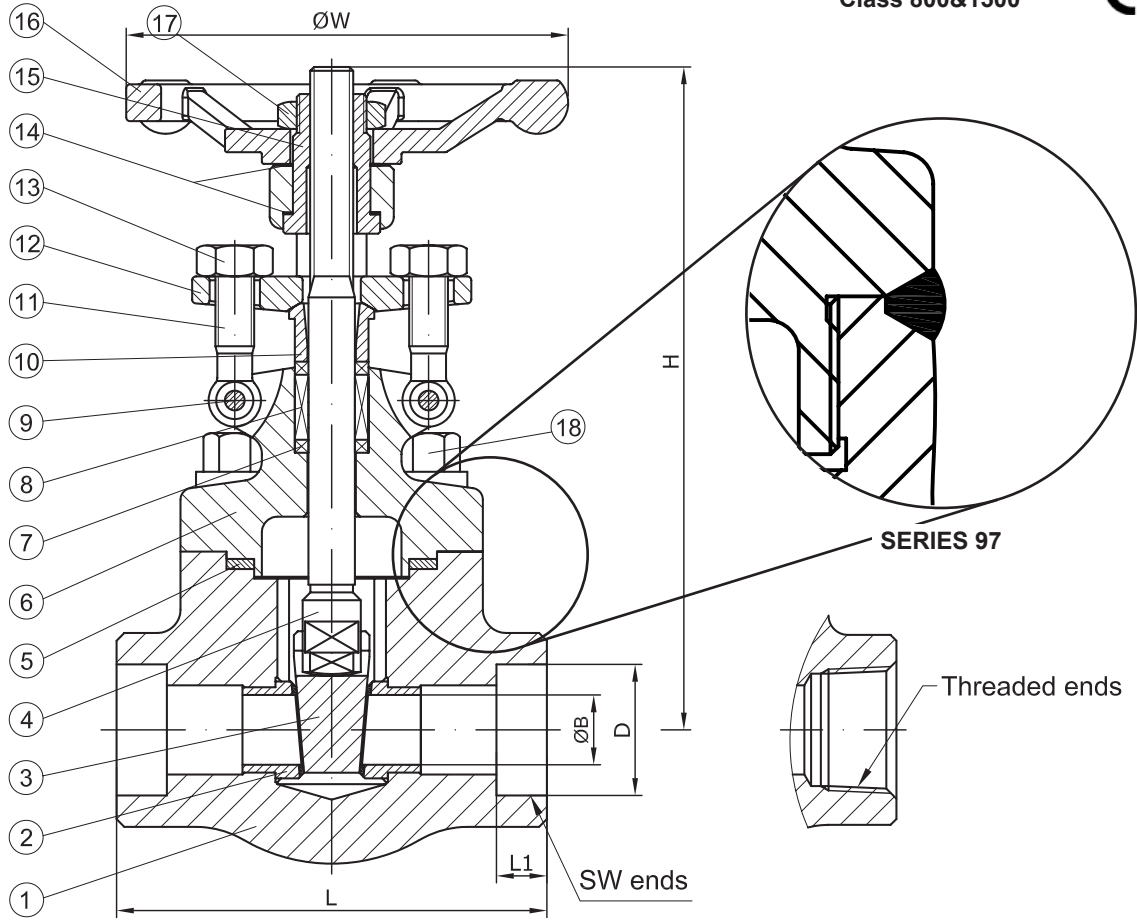

N°	PART	MATERIAL								
		A105N			A350 LF2		A182 F11/F22	A182 F304/F304L	A182 F316/F316L	A182 F51/F53
		Trim 1 (99A01)	Trim 5 (99A05)	Trim 8 (99A08)	Trim 2 (99A12)	Trim 10 (99A1D)	Trim 5 (99B75/99B65)	(99I10/99I90)	(99I30/99I10)	(99K30/99K40)
1	Body	A105N			A350 LF2		A182 F11/F22	A182 F304(L)	A182 F316(L)	A182 F51/F53
2	Seat	A276 410	A276 410+HF	A276 410+HF	A276 304	A276 316	A276 410+HF	A276 304(L)	A276 316(L)	A182 F51/F53
3	Wedge	A182 F6a	A182 F6a+HF	A182 F6a	A182 F304	A182 F316	A182 F6a+HF	A182 F304(L)	A182 F316(L)	A182 F51/F53
4	Stem	A276 410			A276 304	A276 316	A276 410	A276 304(L)	A276 316(L)	A182 F51/F53
5	Bonnet Gasket	SS304+Graphite			SS304+ Graphite	SS316+ Graphite	SS304+ Graphite	SS304+ Graphite	SS316+ Graphite	SS316+ Graphite
6	Bonnet	A105N			A350 LF2		A182 F11/F22	A182 F304(L)	A182 F316(L)	A182 F51/F53
7	Packing	SS304+Graphite			SS304+ Graphite	SS316+ Graphite	SS304+ Graphite	SS304+ Graphite	SS316+ Graphite	SS316+ Graphite
8	Packing	Flexible Graphite			Flexible Graphite		Flexible Graphite	Flexible Graphite	Flexible Graphite	Flexible Graphite
9	Eyebolt Pin	A276 410			A276 410		A276 410	A276 304	A276 304	A276 304
10	Packing Gland	A276 420			A276 304	A276 316	A276 420	A276 304(L)	A276 316(L)	A182 F51/F53
11	Eyebolt	A193 B7			A320 L7		A193 B16	A193 B8(M)	A193 B8M	A193 B8M
12	Gland Flange	A105N			A350 LF2		A182 F11/F22	A182 F304(L)	A182 F316(L)	A182 F51/F53
13	Eyebolt Nut	A194 2H			A194 4		A194 4	A194 8(M)	A194 8M	A194 8M
14	Gasket	A276 410			A276 410		A276 410	A276 304	A276 304	A276 304
15	Stem Nut	A276 410			A276 410		A276 410	A276 410	A276 410	A276 410
16	Handwheel	A197			A197		A197	A197	A197	A197
17	Handwheel Nut	AISI 1035			AISI 1035		AISI 1035	AISI 1035	AISI 1035	AISI 1035
18	Bonnet Bolt	A193 B7			A320 L7		A193 B16	A193 B8(M)	A193 B8M	A193 B8M

HF = Hard faced

Main Valve Parameters

Class 800

Nominal Size		inch	3/8"	1/2"	3/4"	1"	1 1/4"	1 1/2"	2"	
		DN	10	15	20	25	32	40	50	
End connection	Threaded	NPT/BSPT	L	79	79	92	111	120	120	140
			ØB	8	10,5	13,5	18	23	29	36,5
	Socket weld	SW	L	79	79	92	111	120	120	140
			L1	9,6	9,6	12,7	12,7	12,7	12,7	16
ØB			8	10,5	13,5	18	23	29	36,5	
		ØD	17,6	21,8	27,1	33,8	42,6	48,7	61,2	
Top works/Operation	Handwheel	H (open)	159	159	164	188	223	238	265	
		H (close)	135	135	137	160	193	208	234	
		ØW	80	80	80	105	130	130	155	
Kvs-value			-	3,2	5,5	9,7	18,8	29,9	46,1	
Approx. Weight Threaded/SW			2	2	2,2	3	5,2	5,8	8,2	

Dimensions in mm subject to manufacturing tolerance / Kvs-values in m³/h / Weights in kg

Class 1500

Nominal Size		inch	3/8"	1/2"	3/4"	1"	1 1/4"	1 1/2"	2"	
		DN	10	15	20	25	32	40	50	
End connection	Threaded	NPT/BSPT	L	92	111	111	120	120	140	178
			ØB	8	10,5	13,5	18	23	29	36,5
	Socket weld	SW	L	92	111	111	120	120	140	178
			L1	9,6	9,6	12,7	12,7	12,7	12,7	16
ØB			8	10,5	13,5	18	23	29	36,5	
		ØD	17,6	21,8	27,1	33,8	42,6	48,7	61,2	
Top works/Operation	Handwheel	H (open)	180	180	180	223	238	265	316	
		H (close)	160	160	160	192	208	234	283	
		ØW	105	105	105	130	130	155	200	
Kvs-value			-	3,2	5,5	9,7	18,8	29,9	46,1	
Approx. Weight Threaded/SW			3,5	3,5	3,8	5,5	7	9,5	18	

Dimensions in mm subject to manufacturing tolerance / Kvs-values in m³/h / Weights in kg

Main Parts and Materials

SERIES 96 ANSI RANGE
Class 2500

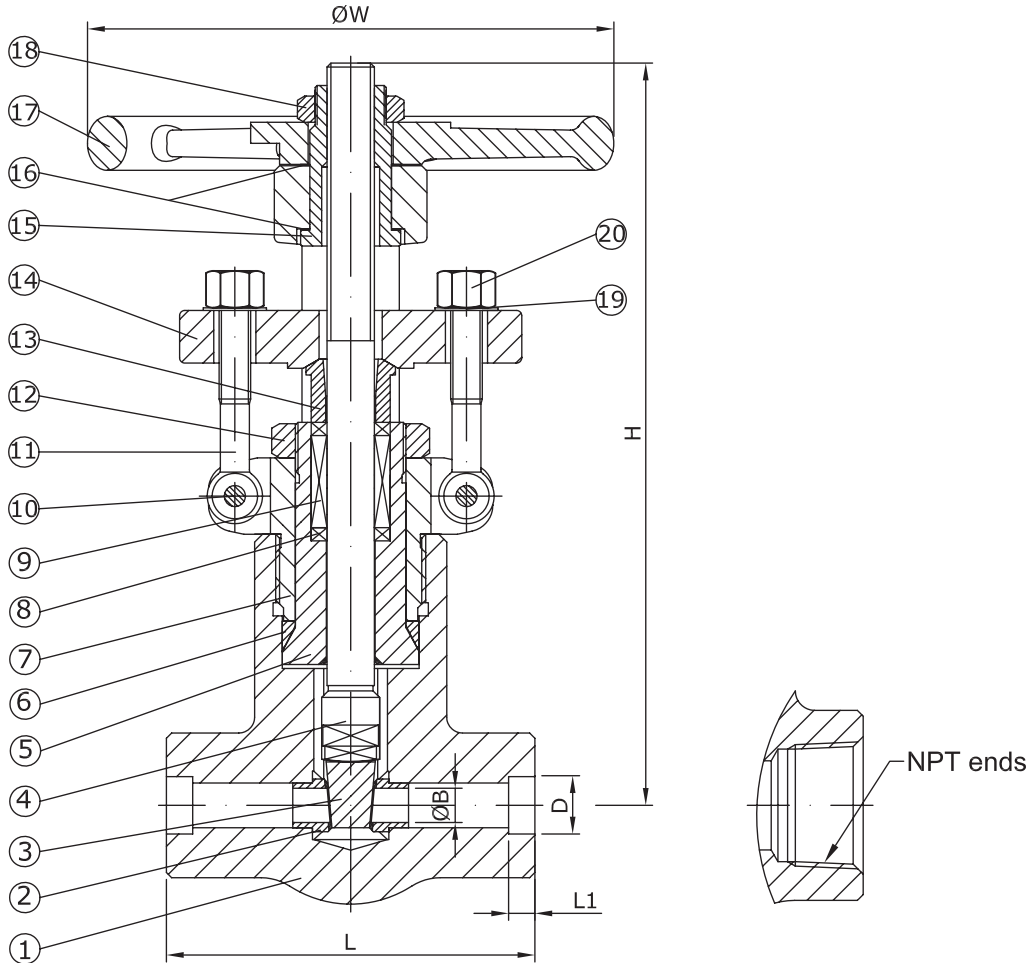

Nº	PART	MATERIAL								
		A105N			A350 LF2		A182 F11/F22	A182 F304/F304L	A182 F316/F316L	A182 F51/F53
		Trim 1 (96A01)	Trim 5 (96A05)	Trim 8 (96A08)	Trim 2 (96A12)	Trim 10 (96A1D)	Trim 5 (96B75/96B65)	(96I10/96I90)	(96I30/96I10)	(96K30/96K40)
1	Body	A105N			A350 LF2		A182 F11/F22	A182 F304(L)	A182 F316(L)	A182 F51/F53
2	Seat	A276 410	A276 410+HF	A276 410+HF	A276 304	A276 316	A276 410+HF	A276 304(L)	A276 316(L)	A182 F51/F53
3	Wedge	A182 F6a	A182 F6a+HF	A182 F6a	A182 F304	A182 F316	A182 F6a+HF	A182 F304(L)	A182 F316(L)	A182 F51/F53
4	Stem	A276 410			A276 304	A276 316	A276 410	A276 304(L)	A276 316(L)	A182 F51/F53
5	Seal Nut	A276 420			A276 304	A276 316	A276 420	A276 304(L)	A276 316(L)	A182 F51/F53
6	Gasket	A276 304			A276 304		A276 304	A276 304(L)	A276 316(L)	A182 F51/F53
7	Bonnet	A105N			A350 LF2		A182 F11/F22	A182 F304(L)	A182 F316(L)	A182 F51/F53
8	Packing	SS304+Graphite			SS304+ Graphite	SS316+ Graphite	SS304+ Graphite	SS304+ Graphite	SS316+ Graphite	SS316+ Graphite
9	Packing	Flexible Graphite			Flexible Graphite		Flexible Graphite	Flexible Graphite	Flexible Graphite	Flexible Graphite
10	Eyebolt Pin	A276 410			A276 410		A276 410	A276 304	A276 304	A276 304
11	Eyebolt	A193 B7			A320 L7		A193 B16	A193 B8(M)	A193 B8M	A193 B8M
12	Lock Nut	Carbon Steel			Carbon Steel		Carbon Steel	St.Steel	St.Steel	St.Steel
13	Packing Gland	A276 420			A276 304	A276 316	A276 420	A276 304(L)	A276 316(L)	A182 F51/F53
14	Gland Flange	A105N			A350 LF2		A182 F11/F22	A182 F304(L)	A182 F316(L)	A182 F51/F53
15	Stem Nut	A276 410			A276 410		A276 410	A276 410	A276 410	A276 410
16	Gasket	A276 410			A276 410		A276 410	A276 304	A276 304	A276 304
17	Handwheel	A197			A197		A197	A197	A197	A197
18	Handwheel Nut	AISI 1035			AISI 1035		AISI 1035	AISI 1035	AISI 1035	AISI 1035
19	Washer	Carbon Steel			Carbon Steel		Carbon Steel	St.Steel	St.Steel	St.Steel
20	Eyebolt Nut	A194 2H			A194 4		A194 4	A194 8(M)	A194 8M	A194 8M

HF = Hard faced

Information / restriction of technical rules need to be observed!
Installation, Operating and Maintenance Manual can be downloaded at www.comeval.es

The engineer, designing a system or a plant, is responsible for the selection of the correct valve
Product suitability must be verified, contact manufacturer for information

Main Valve Parameters

Class 2500

Nominal Size		inch	3/8"	1/2"	3/4"	1"	1 1/4"	1 1/2"	2"		
DN			10	15	20	25	32	40	50		
End connection	Threaded	NPT/ BSP/BSPT	L	92	111	111	120	120	140	178	
			ØB	8	10,5	13,5	18	23	29	36,5	
		Socket weld	SW	L	92	111	111	120	120	140	178
				L1	9,6	9,6	12,7	12,7	12,7	12,7	16
	ØB			8	10,5	13,5	18	23	29	36,5	
	ØD			17,6	21,8	27,1	33,8	42,6	48,7	61,2	
	Top works/ Operation	Handwheel	H (open)	180	180	180	223	238	265	316	
			H (close)	160	160	160	192	208	234	283	
ØW			100	120	120	160	160	180	200		
Kvs-value			-	3,2	5,5	9,7	18,8	29,9	46,1		
Approx. Weight Threaded/SW			3,5	3,5	3,8	5,5	7	9,5	18		

Dimensions in mm subject to manufacturing tolerance / Kvs-values in m³/h / Weights in kg