

## Spolehlivý spojovací systém s nástrčným kuželem a převlečnou maticí

- kovové provedení (Ms) se zušlechtěným povrchem (galvanicky poniklováno)
- pojištění hadice za vnější průměr pomocí převlečné matice
- utěsnění hadice za vnitřní průměr pomocí kužele
- utěsnění závitu integrovaným O-kroužkem (nejsou nutné těsnicí kroužky)

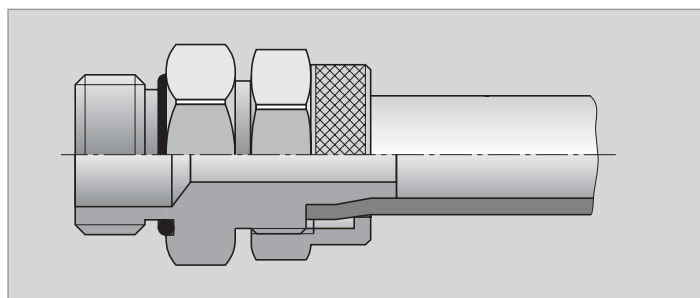
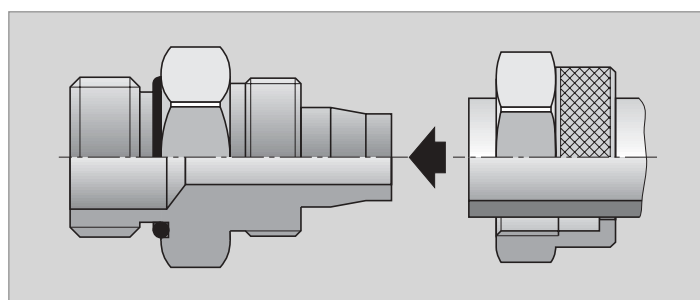

Technické údaje	
Připojovací závit*	M5, G1/8, G1/4, G3/8, G1/2 (válcový a kuželový)
Venkovní/vnitřní průměr hadice*	4/2, 5/3, 6/4, 8/6, 10/8, 12/10, 15/12,5
Materiál**	Těleso matice: mosaz galvanicky poniklována, O-kroužek: NBR
Rozsah pracovního tlaku	0 až 18 bar (vhodné pro vakuum)
Rozsah teplot	-25 °C až +80 °C (jiné teploty konzultovat)
Médium	Tlakový vzduch (jiná média po konzultovat)

\* dle provedení

\*\* výjimky jsou zde vyznačeny

Doporučené hadice <sup>1)</sup>	
Provedení hadice	hadice pro tlakový vzduch
Tolerance hadice	obvyklé tolerance
Materiál hadice	PE, PA, PU, PVC (zesílené skelným vláknem) podle použití

<sup>1)</sup> viz naše nabídka hadic: odstavec hadice, strany 107–109

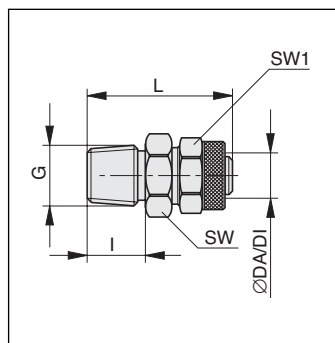
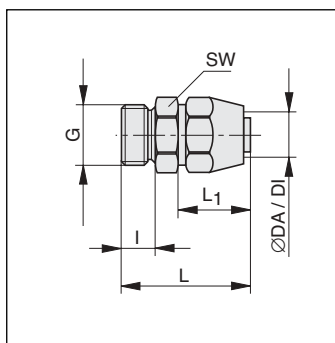
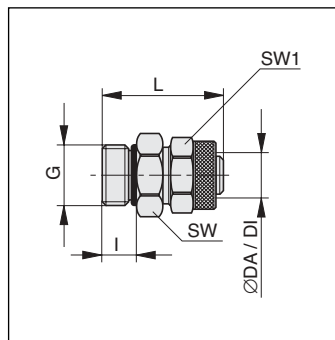

Přímé šroubení s válcovým závitem (s O-kroužkem)								
Údaje pro objednávku		NW	Hadice ØDA/DI	G	SW	SW1	I	L
Typ	Obj. číslo							
G-54Msv	KW 0178	1,5	4/2	M5	8	9	4	22
G-55Msv	KW 0181	2	5/3	M5	8	8	4	22
G-185Msv	KW 0182	2	5/3	G1/8	14	8	6	23
G-56Msv	KW 0183	2,5	6/4	M5	9	9	4	22
G-186Msv	KW 0184	3	6/4	G1/8	15	12	6	25
G-146Msv	KW 0185	3	6/4	G1/4	18	12	8	27
G-188Msv	KW 0186	5	8/6	G1/8	15	14	6	25
G-148Msv	KW 0187	5	8/6	G1/4	18	14	8	27
G-388Msv	KW 0188	5	8/6	G3/8	21	14	9	29
G-1410Msv	KW 0189	6,8	10/8	G1/4	18	16	8	29
G-3810Msv	KW 0190	6,8	10/8	G3/8	21	16	9	31
G-1210Msv	KW 0191	6,8	10/8	G1/2	26	16	11	33
G-3812Msv	KW 0192	8,5	12/10	G3/8	21	19	9,0	33
G-1212Msv	KW 0193	8,5	12/10	G1/2	26	19	11	35
G-1215Msv	KW 0194	11	15/12,5	G1/2	26	22	11	35,5

Přímé šroubení pro hadici s kovovým opletením								
Údaje pro objednávku		NW	Hadice ØDA/DI	G	SW	I	L <sub>1</sub>	L <sub>2</sub>
Typ	Obj. číslo							
G-146M	KX 5517	5,2	9/6	G1/4	17	9	35	20,5
G-149M	KX 5518	7,5	12/9	G1/4	22	9	38	23
G-386M	KX 5519	5,2	9/6	G3/8	19	9	35	20,5
G-389M	KX 5520	7,5	12/9	G3/8	22	9	38	23
G-126M	KX 5521	5,2	9/6	G1/2	24	11	37,5	20,5
G-129M	KX 5522	7,5	12/9	G1/2	24	11	40	23

Přímé šroubení s kuželovým závitem								
Údaje pro objednávku		NW	Hadice ØDA/DI	G	SW	SW1	I	L
Typ	Obj. číslo							
GK-185Msv	KW 0166	2,0	5/3	R1/8	12	8	8	24,5
GK-186Msv	KW 0167	3,0	6/4	R1/8	12	12	8	26,5
GK-146Msv	KW 0168	3,0	6/4	R1/4	14	12	11	30
GK-188Msv	KW 0169	5,0	8/6	R1/8	12	14	8	26
GK-148Msv	KW 0170	5,0	8/6	R1/4	14	14	11	30
GK-388Msv	KW 0171	5,0	8/6	R3/8	17	14	11,5	31
GK-1810Msv	KW 0838	6,8	10/8	R1/8	14	16	8	28,5
GK-1410Msv	KW 0172	6,8	10/8	R1/4	14	16	11	32
GK-3810Msv	KW 0173	6,8	10/8	R3/8	17	16	11,5	33
GK-1210Msv	KW 0174	6,8	10/8	R1/2	22	16	14	36
GK-3812Msv	KW 0175	8,5	12/10	R3/8	17	19	11,5	35
GK-1212Msv	KW 0176	8,5	12/10	R1/2	22	19	14	38
GK-1215Msv	KW 0177	10,5	15/12,5	R1/2	22	22	14	39,5

Manometrové šroubení								
Údaje pro objednávku		NW	Hadice Ø DA/DI	G	SW	SW1	I	L
Typ	Obj. číslo							
MV-186Msv	KW 0195	3	6/4	G1/8	14	12	7	26
MV-146Msv	KW 0196	3	6/4	G1/4	17	12	8	28
MV-188Msv	KW 0197	5	8/6	G1/8	14	14	7	26
MV-148Msv	KW 0198	5	8/6	G1/4	17	14	8	28
MV-388Msv	KW 0199	5	8/6	G3/8	20	14	10,3	32
MV-1410Msv	KW 0200	6,8	10/8	G1/4	17	16	8	30
MV-3810Msv	KW 0201	6,8	10/8	G3/8	20	16	10,3	34
MV-1210Msv	KW 0202	6,8	10/8	G1/2	24	16	11,4	37,5

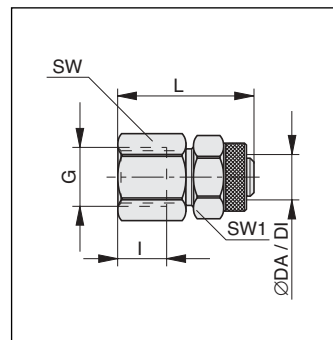

Rohové šroubení otočné s válcovým závitem (s O-kroužkem)										
Údaje pro objednávku		NW	Hadice Ø DA/DI	G	SW	SW1	SW2	I	L	L <sub>1</sub>
Typ	Obj. číslo									
LD-186Msv	KW 0964	3	6/4	G1/8	10	12	13	6	21	20,5
LD-146Msv	KW 0965	3	6/4	G1/4	10	12	16	8	22,5	21,6
LD-188Msv	KW 0966	6	8/6	G1/8	10	14	13	6	21	21
LD-148Msv	KW 0967	6	8/6	G1/4	12	14	16	8	24	22
LD-1410Msv	KW 0968	6,8	10/8	G1/4	12	16	16	8	24	24

Při mnoha otočných pohybech typ ES-..

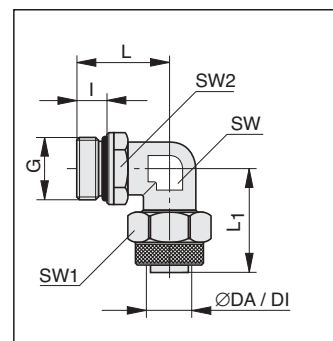
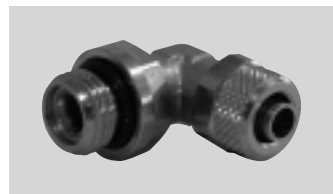

Jednoduché otočné šroubení (s O-kroužkem)											
Údaje pro objednávku		NW	Hadice Ø DA/DI	G	SW	SW1	Ø D	I	L	L <sub>1</sub>	L <sub>2</sub>
Typ	Obj. číslo										
ES-54Msv	KW 0323	1,5	4/2	M5	2	9	9,9	4	20	16,8	6,5
ES-185Msv	KW 0325	2	5/3	G1/8	5	8	15	6	17	27	10,5
ES-56Msv	KW 0326	3	6/4	M5	2	9	9,9	4	20,5	16,8	6,5
ES-186Msv	KW 0327	3	6/4	G1/8	5	12	15	6	24	27	10,5
ES-146Msv	KW 0328	3	6/4	G1/4	6	12	18	8	26,5	31,5	11,5
ES-188Msv	KW 0329	5	8/6	G1/8	5	14	15	6	24	27	10,5
ES-148Msv	KW 0330	5	8/6	G1/4	6	14	18	8	26	31,5	11,5
ES-388Msv	KW 0331	5	8/6	G3/8	6	14	21	9	28	36	13,5
ES-1410Msv	KW 0332	6,8	10/8	G1/4	6	16	18	8	28	31,5	11,5
ES-3810Msv	KW 0333	6,8	10/8	G3/8	6	16	21	9	29	36	13,5
ES-1210Msv	KW 0334	6,8	10/8	G1/2	10	16	26	11	30,5	32	15,5
ES-3812Msv	KW 0335	8,5	12/10	G3/8	6	19	21	9	31,5	36	13,5
ES-1212Msv	KW 0336	8,5	12/10	G1/2	10	19	26	11	33	42	15,5
ES-1215Msv	KW 0829	11	15/12,5	G1/2	10	22	26	11	35	42	15,5

Použití: při mnoha otočných pohybech

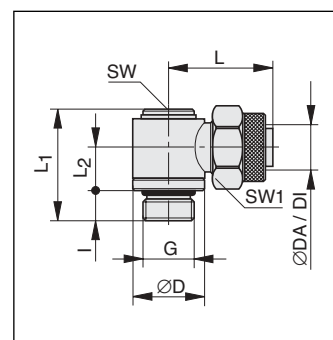

Rozměry v mm

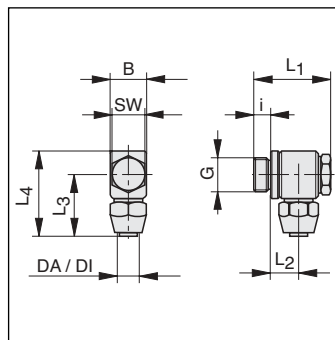

Jednoduché otočné šroubení pro hadici s kovovým opletením											
Údaje pro objednávku		NW	Hadice ØDA/DI	G	B	I	L <sub>1</sub>	L <sub>2</sub>	L <sub>3</sub>	L <sub>4</sub>	SW
Typ	Obj. číslo										
ES-146M	KX 5540	5,2	9/6	G1/4	20	6,5	37	14,5	30	39,5	17
ES-149M	KX 5541	6,5	12/9	G1/4	20	6,5	40	16	32,5	42	17
ES-389M	KX 5542	7	12/9	G3/8	24	6,5	41	16	35	47	22

Materiál: hliník černě eloxovaný

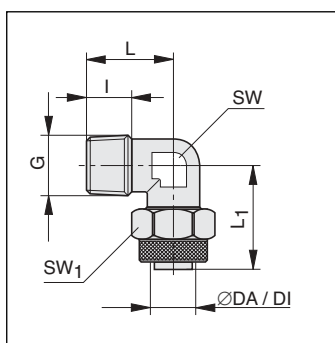

Úhlové šroubení s kuželovým závitem									
Údaje pro objednávku		NW	Hadice ØDA/DI	G	SW	SW1	I	L	L <sub>1</sub>
Typ	Obj. číslo								
WE-185Msv	KW 0215	2	5/3	R1/8	8	8	8	17	21,5
WE-186Msv	KW 0216	3	6/4	R1/8	9	12	8	17	22
WE-146Msv	KW 0217	3	6/4	R1/4	9	12	11	20	22
WE-188Msv	KW 0218	5	8/6	R1/8	12	14	8	17	22
WE-148Msv	KW 0219	5	8/6	R1/4	12	14	11	20	22
WE-388Msv	KW 0220	5	8/6	R3/8	12	14	11,5	22	22,5
WE-1810Msv	KW 0874	6,8	10/8	R1/8	11	16	8	20,5	25,5
WE-1410Msv	KW 0221	6,8	10/8	R1/4	12	16	11	22	24,5
WE-3810Msv	KW 0222	6,8	10/8	R3/8	12	16	11,5	22	24,5
WE-1210Msv	KW 0223	6,8	10/8	R1/2	17	16	14	26	27,5
WE-3812Msv	KW 0224	8,5	12/10	R3/8	17	19	11,5	24,5	31
WE-1212Msv	KW 0225	8,5	12/10	R1/2	17	19	14	26	31
WE-1215Msv	KW 0226	11	15/12,5	R1/2	17	22	14	28	34

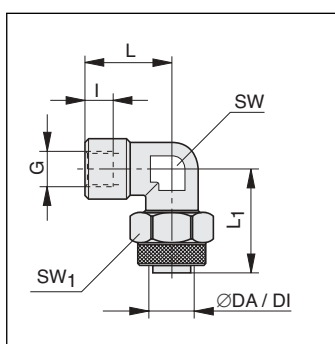

Úhlové šroubení s válcovým závitem									
Údaje pro objednávku		NW	Hadice ØDA/DI	G	SW	SW1	I	L	L <sub>1</sub>
Typ	Obj. číslo								
WI-185Msv	KW 0963	2	5/3	G1/8	8	8	7	21,5	22
WI-186Msv	KW 0227	3	6/4	G1/8	9	12	7	20	22
WI-146Msv	KW 0228	3	6/4	G1/4	11	12	8	23	25,5
WI-188Msv	KW 0229	5	8/6	G1/8	10	14	7	21	22,5
WI-148Msv	KW 0230	5	8/6	G1/4	12	14	8	22,5	22
WI-1410Msv	KW 0231	6,8	10/8	G1/4	11	16	8	23	25,5

# Kovové šroubení

Jednoduchá kruhová objímka k dutému šroubu*								
Údaje pro objednávku		NW	Hadice Ø DA/DI	Ø B pro duté šrouby	SW	Ø D	L	L <sub>1</sub>
Typ	Obj. číslo							
RE-54Msv	KW 0270	1,5	4/2	M5	9	9,5	9	19
RE-55Msv	KW 0274	2	5/3	M5	8	9,5	9	20,5
RE-185Msv	KW 0275	2	5/3	G1/8	8	14	15	24
RE-56Msv	KW 0276	3	6/4	M5	9	9,5	9	20,5
RE-186Msv	KW 0277	3	6/4	G1/8	12	14	15	24
RE-146Msv	KW 0278	3	6/4	G1/4	12	18	17	26
RE-188Msv	KW 0279	5	8/6	G1/8	14	14	15	24
RE-148Msv	KW 0280	5	8/6	G1/4	14	18	17	26
RE-388Msv	KW 0281	5	8/6	G3/8	14	21	20	28
RE-1410Msv	KW 0282	6,8	10/8	G1/4	16	18	17	28
RE-3810Msv	KW 0283	6,8	10/8	G3/8	16	21	20	28
RE-1210Msv	KW 0284	6,8	10/8	G1/2	16	26	24	30,5
RE-3812Msv	KW 0285	8,5	12/10	G3/8	19	21	20	31,5
RE-1212Msv	KW 0286	8,5	12/10	G1/2	19	26	24	33
RE-1215Msv	KW 0287	11	15/12,5	G1/2	22	26	24	35

\* duté šrouby viz strany 91–93

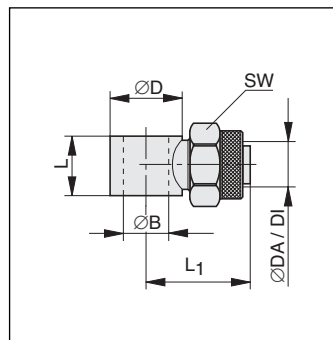

Jednoduchá kruhová objímka k dutému šroubu*								
Údaje pro objednávku		NW	Ø B pro duté šrouby	G	Ø D	Ø D <sub>1</sub>	l	L
Typ	Obj. číslo							
REI-1818Msv	KW 0346	3	G1/8	G1/8	14	13,3	7	15
REI-1414Msv	KW 0347	5	G1/4	G1/4	18	16,7	8	17
REI-3838Msv	KW 0348	8,5	G3/8	G3/8	21	20,2	10,3	20

\* duté šrouby viz strany 91–93

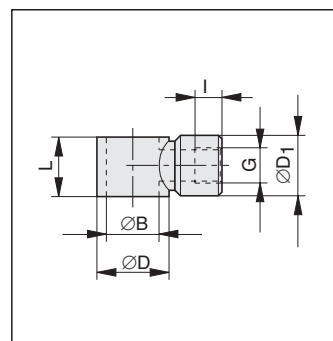

L-šroubení s kuželovým závitem									
Údaje pro objednávku		NW	Hadice Ø DA/DI	F	SW	SW1	l	L	L <sub>1</sub>
Typ	Obj. číslo								
LE-185Msv	KW 0250	2	5/3	R1/8	12	8	8	38,5	21,5
LE-186Msv	KW 0251	3	6/4	R1/8	12	9	8	39	22
LE-146Msv	KW 0252	3	6/4	R1/4	12	9	11	42	22
LE-188Msv	KW 0253	5	8/6	R1/8	12	14	8	39	22
LE-148Msv	KW 0254	5	8/6	R1/4	12	14	11	42	22
LE-388Msv	KW 0255	5	8/6	R3/8	12	14	11,5	44,5	22,5
LE-1410Msv	KW 0256	6,8	10/8	R1/4	12	16	11	46,5	24,5
LE-3810Msv	KW 0257	6,8	10/8	R3/8	12	16	11,5	46,5	24,5
LE-1210Msv	KW 0258	6,8	10/8	R1/2	17	16	14	53,5	27,5
LE-3812Msv	KW 0259	8,5	12/10	R3/8	17	19	11,5	55	31
LE-1212Msv	KW 0260	8,5	12/10	R1/2	17	19	14	57	31

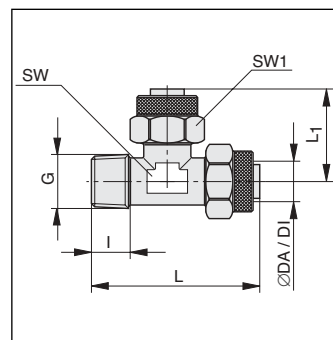

Rozměry v mm

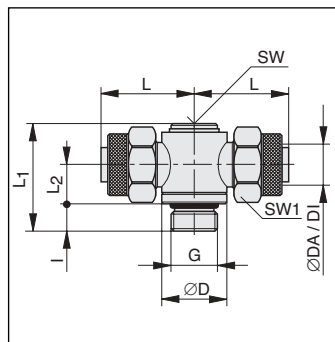

T-otočné šroubení s válcovým závitem (s O-kroužkem)											
Údaje pro objednávku		NW	Hadice ØDA/DI	G	SW	SW1	ØD	I	L	L <sub>1</sub>	L <sub>2</sub>
Typ	Obj. číslo										
TS-186Msv	KW 0337	2	6/4	G1/8	5	12	15	6	24	27	10,5
TS-146Msv	KW 0338	3	6/4	G1/4	6	12	18	8	26	31,5	11,5
TS-188Msv	KW 0339	3	8/6	G1/8	5	14	15	6	24	27	10,5
TS-148Msv	KW 0340	5	8/6	G1/4	6	14	18	8	26	31,5	11,5
TS-388Msv	KW 0341	5	8/6	G3/8	6	14	21	9	28	36	13,5
TS-1410Msv	KW 0342	5	10/8	G1/4	6	16	18	8	27,5	31,5	11,5
TS-3810Msv	KW 0343	6,8	10/8	G3/8	6	16	21	9	29	36	13,5
TS-1210Msv	KW 0344	6,8	10/8	G1/2	10	16	26	11	30,5	42	15,5
TS-3812Msv	KW 0345	6,8	12/10	G3/8	6	19	21	9	31,5	36	13,5
TS-1212Msv	KW 0830	8,5	12/10	G1/2	10	19	26	11	33	42	19,5

Použití: při mnoha otočných pohybech

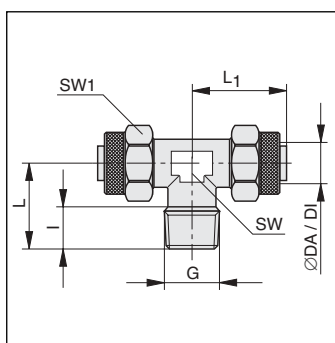

T-šroubení s kuželovým závitem									
Údaje pro objednávku		NW	Hadice Ø DA/DI	G	SW	SW1	I	L	L <sub>1</sub>
Typ	Obj. číslo								
TE-185Msv	KW 0238	2	5/3	R1/8	8	8	8	17	21,5
TE-186Msv	KW 0239	3	6/4	R1/8	12	9	8	17	22
TE-146Msv	KW 0240	3	6/4	R1/4	12	9	11	20	22
TE-188Msv	KW 0241	5	8/6	R1/8	12	14	8	17	22
TE-148Msv	KW 0242	5	8/6	R1/4	12	14	11	20	22
TE-388Msv	KW 0243	5	8/6	R3/8	12	14	11,5	22	22,5
TE-1410Msv	KW 0244	6,8	10/8	R1/4	12	16	11	22	24,5
TE-3810Msv	KW 0245	6,8	10/8	R3/8	12	16	11,5	22	24,5
TE-1210Msv	KW 0246	6,8	10/8	R1/2	17	16	14	26	27,5
TE-3812Msv	KW 0247	8,5	12/10	R3/8	17	19	11,5	24	31
TE-1212Msv	KW 0248	8,5	12/10	R1/2	17	19	14	26	31
TE-1215Msv	KW 0249	11	15/12,5	R1/2	17	22	14	28	34

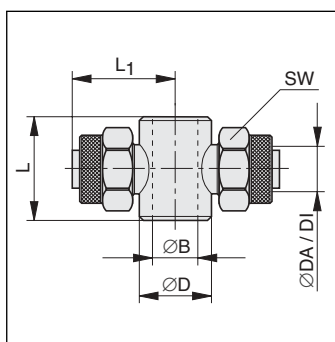
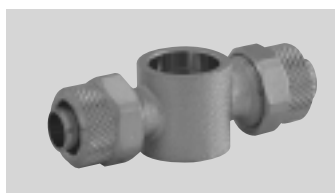

Dvojitá kruhová objímka k dutému šroubu								
Údaje pro objednávku		NW	Hadice Ø DA/DI	Ø B pro dutý šroub	SW	Ø D	L	L <sub>1</sub>
Typ	Obj. číslo							
RD-185Msv	KW 0288	2	5/3	G1/8	8	14	15	24
RD-186Msv	KW 0289	3	6/4	G1/8	12	14	15	24
RD-146Msv	KW 0290	3	6/4	G1/4	12	18	17	26
RD-188Msv	KW 0291	5	8/6	G1/8	14	14	15	24
RD-148Msv	KW 0292	5	8/6	G1/4	14	18	17	26
RD-388Msv	KW 0293	5	8/6	G3/8	14	21	20	28
RD-1410Msv	KW 0294	6,8	10/8	G1/4	16	18	17	28
RD-3810Msv	KW 0295	6,8	10/8	G3/8	16	21	20	28
RD-1210Msv	KW 0296	6,8	10/8	G1/2	16	26	24	30,5
RD-1212Msv	KW 0297	8,5	12/10	G1/2	19	26	24	33

\* duté šrouby viz strany 91–93

# Kovové šroubení

Dvojitě šroubení						
Údaje pro objednávku		NW	Hadice Ø DA/DI	SW	SW1	L
Typ	Obj. číslo					
GV-5Msv	KW 0203	2	5/3	8	8	28,5
GV-6Msv	KW 0204	3	6/4	12	12	33
GV-8Msv	KW 0205	5	8/6	12	14	33
GV-10Msv	KW 0206	6,8	10/8	14	16	37
GV-12Msv	KW 0207	8,5	12/10	17	19	42
GV-15Msv	KW 0208	11	15/12,5	22	22	45

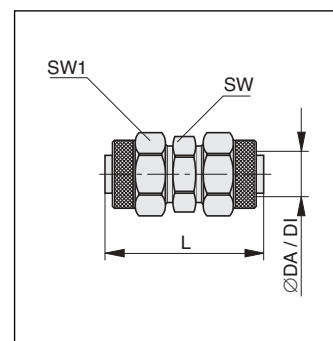

Přepážkové Schott-šroubení							
Údaje pro objednávku		NW	Hadice Ø DA/DI	SW	SW1	L	B
Typ	Obj. číslo						
SV-53Msv	KW 0209	2	5/3	8	8	40	9
SV-64Msv	KW 0210	3	6/4	14	12	47	11
SV-86Msv	KW 0211	5	8/6	16	14	48	13
SV-108Msv	KW 0212	6,8	10/8	17	16	49	10,5
SV-1210Msv	KW 0213	8,5	12/10	19	19	53	10
SV-1512Msv	KW 0214	11	15/12,5	24	22	53	10

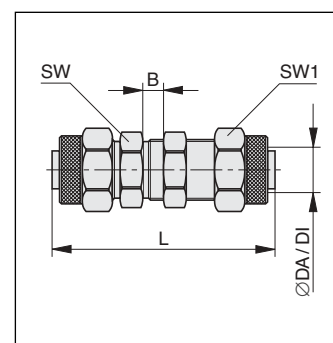
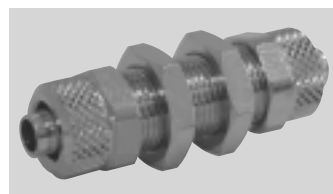

Úhlové šroubení						
Údaje pro objednávku		NW	Hadice Ø DA/DI	SW	SW1	L
Typ	Obj. číslo					
W-5Msv	KW 0232	2	5/3	8	8	21
W-6Msv	KW 0233	3	6/4	9	12	22
W-8Msv	KW 0234	5	8/6	12	14	22
W-10Msv	KW 0235	6,8	10/8	12	16	24,5
W-12Msv	KW 0236	8,5	12/10	17	19	31
W-15Msv	KW 0237	11	15/12,5	17	22	34

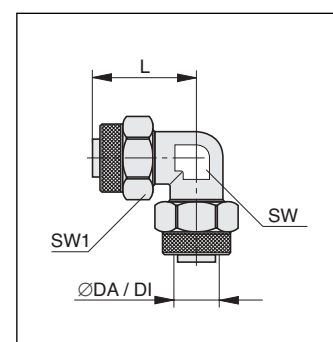
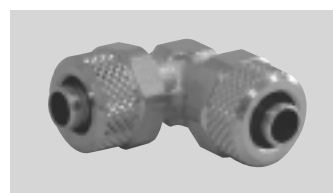

## Šroubení

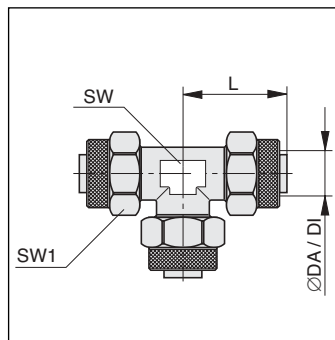
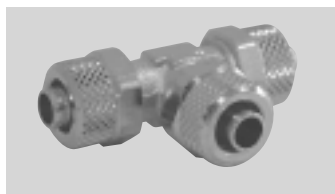

T šroubení						
Údaje pro objednávku		NW	Hadice ØDA/DI	SW	SW1	L
Typ	Obj. číslo					
TV-5Msv	KW 0261	2	5/3	8	8	21
TV-6Msv	KW 0262	3	6/4	9	12	22
TV-8Msv	KW 0263	5	8/6	12	14	22
TV-10Msv	KW 0264	6,8	10/8	12	16	24,5
TV-12Msv	KW 0265	8,5	12/10	17	19	31
TV-15Msv	KW 0266	11	15/12,5	17	22	34

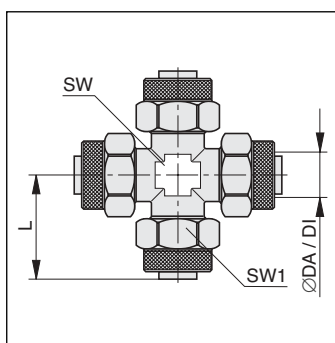
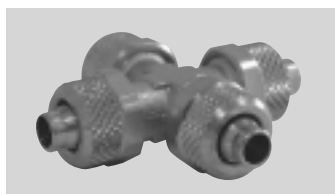

Křížové šroubení						
Údaje pro objednávku		NW	Hadice ØDA/DI	SW	SW1	L
Typ	Obj. číslo					
KV-6Msv	KW 0267	3	6/4	9	12	21
KV-8Msv	KW 0268	5	8/6	12	14	22,5
KV-10Msv	KW 0269	6,8	10/8	12	16	26,5

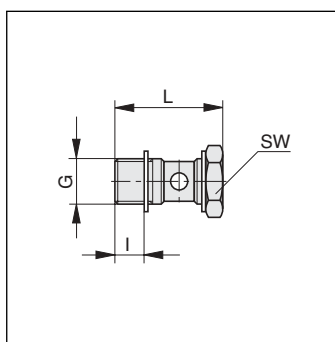

Jednoduchý dutý šroub kompletní pro kruhovou objímku*						
Údaje pro objednávku		NW	G	SW	I	L
Typ	Obj. číslo					
H-15Msv	KW 0298	2	M5	8	6	18
H-118Msv	KW 0299	3	G1/8	14	9	28
H-114Msv	KW 0300	5	G1/4	17	11	33
H-138Msv	KW 0301	6,8	G3/8	20	12	37
H-112Msv	KW 0302	8,5	G1/2	27	13	42

\* kruhové objímky viz strany 87, 88



# Kovové šroubení

Dvojitý dutý šroub kompletní pro kruhové objímky*						
Údaje pro objednávku		NW	G	SW	I	L
Typ	Obj. číslo					
H-218Msv	KW 0307	3	G1/8	14	9	44,5
H-214Msv	KW 0308	5	G1/4	17	11	51,5
H-238Msv	KW 0309	6,8	G3/8	20	12	58,5
H-212Msv	KW 0310	8,5	G1/2	27	13	67,5

\* kruhové objímky viz strany 87, 88

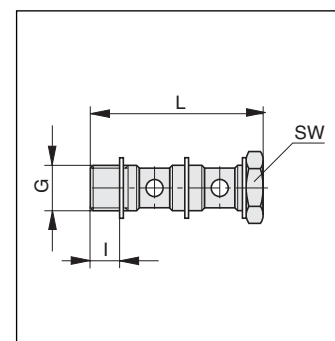

Dvojitý dutý šroub kompletní pro kruhové objímky*						
Údaje pro objednávku		NW	G	SW	I	L
Typ	Obj. číslo					
H-318Msv	KW 0972	3	G1/8	14	9	61
H-314Msv	KW 0973	5	G1/4	17	11	70

\* kruhové objímky viz strany 87, 88

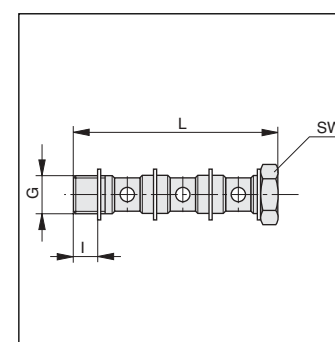

Jednoduchý dutý šroub kompletní pro kruhové objímky*								
Údaje pro objednávku		NW	G	G <sub>1</sub>	SW	I	I <sub>1</sub>	L
Typ	Obj. číslo							
HI-118Msv	KW 0303	3	G1/8	G1/8	14	9	7	36,5
HI-114Msv	KW 0304	5	G1/4	G1/4	17	11	8	42
HI-138Msv	KW 0305	6,8	G3/8	G3/8	20	12	10,3	49,5
HI-112Msv	KW 0306	8,5	G1/2	G1/2	27	13	11,4	55

\* kruhové objímky viz strany 87, 88

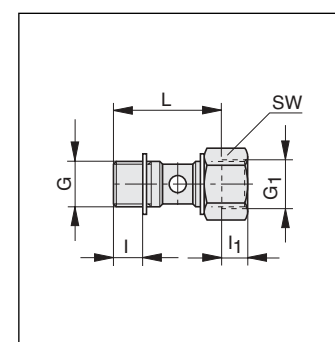

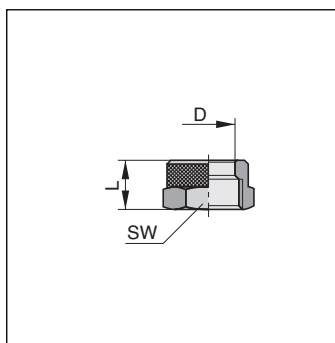
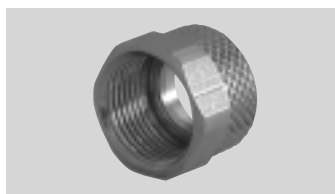
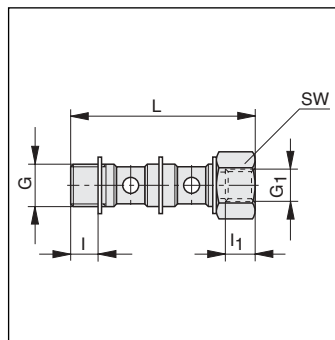
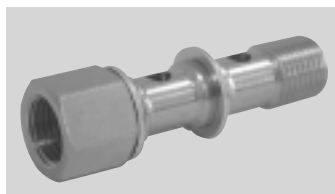

Dvojitý dutý šroub kompletní pro kruhové objímky								
Údaje pro objednávku		NW	G	G <sub>1</sub>	SW	I	I <sub>1</sub>	L
Typ	Obj. číslo							
HI-218Msv	KW 0311	3	G1/8	G1/8	14	9	7	53
HI-214Msv	KW 0312	5	G1/4	G1/4	17	11	8	60,5
HI-238Msv	KW 0313	6,8	G3/8	G3/8	20	12	10,3	71
HI-212Msv	KW 0314	8,5	G1/2	G1/2	27	13	11,4	80,5

\* kruhové objímky viz strany 87, 88

Převlečná matice pro šroubení					
Údaje pro objednávku		Pro šroubení s připojovacím závitem	Hadice Ø DA/DI	L	SW1
Typ	Obj. číslo				
UM-4Msv	KW 0710	M5	4/2	9	9
UM-5Msv	KW 0711	M5, G1/8	5/3	8	8
UM-6/1Msv	KW 0712	M5	6/4	9	9
UM-6/2Msv	KW 0713	G1/8, G1/4	6/4	11	12
UM-8Msv	KW 0714	G1/8, G1/4, G3/8	8/6	11	14
UM-10Msv	KW 0715	G1/4, G3/8, G1/2	10/8	12	16
UM-12Msv	KW 0716	G3/8, G1/2	12/10	12	19
UM-15Msv	KW 0717	G1/2	15/12,5	13	22