

2 STANDARD

FORGED STEEL BALL VALVES



PED 97/23 EC



Certificate N°: RPS 0160304/01

ATEX 94/9 CE



Tech. File N° ST01 ATEX



P-8871



MAC/10699/2/TO/99



6D-0233



TYPE APPROVED

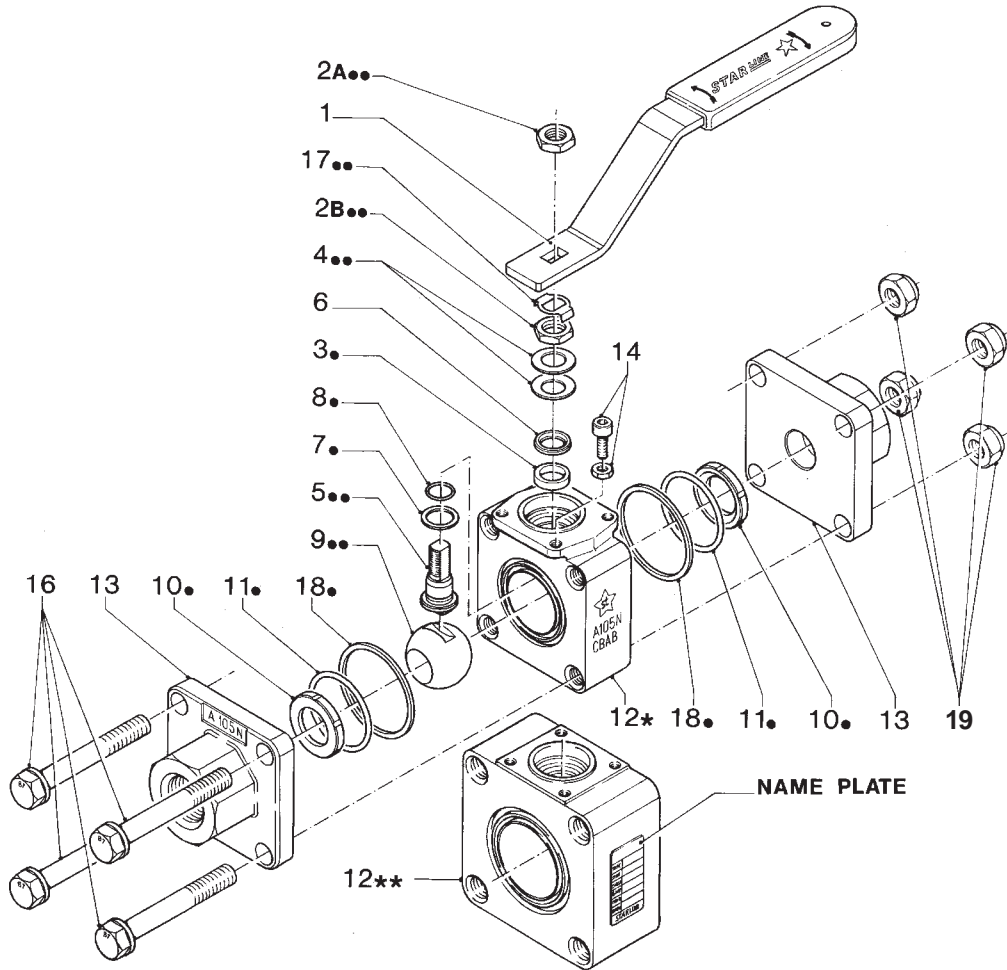

• Suggested materials after 2 years service
 • Empfohlene ersatzteile für 2. Jahres betrieb
 • Pièces de rechange conseillées pour 2 ans de service
 • Recambios aconsejados para 2 años de servicio

•• Suggested materials after 5 years service
 •• Empfohlene ersatzteile für 5. Jahres betrieb
 •• Pièces de rechange conseillées pour 5 ans de service
 •• Recambios aconsejados para 5 años de servicio

★ Body shape for size
 1/4" to 3/4" Full Bore
 1/2" to 1" Reduced Bore

★★ Body shape for size
 1" to 1.1/2" Full Bore
 1.1/4" to 2" Reduced Bore

STARLINE			FULL BORE	N 123 SGV	N 126 TGT
Figure No.			REGULAR BORE	N 223 SGV	N 226 TGT
ITEM	Q.TY	Part name Bezeichnung	Designation Componentes	A105/F316	F316/F316
1	1	Handle Handhebel	Levier Maneta	C.S. Galvanized Plastic cover	C.S. Galvanized Plastic cover
••2 A B	2	Nut Mutter	Ecrou Tuerca	C.S. Cadmium Plated	S.S. 316
• 3	1	Packing ring Stopfbuchsenpackung	Guamiture Junta eje	Graphite	Graphite
•• 4	2	Spring washer Tellerfedern	Rondelle ressort Arandela	Special S.S.	Special S.S.
•• 5	1	Antistatic stem Antistatische spindel	Tige antistatique Eje antiestatico	S.S. 316	S.S. 316
6	1	Gland packing Druck ring	Fouloir Estopada	S.S. 316	S.S. 316
• 7	1	Thrust washer Spindeldichtung	Rondelle butée Junta eje	Reinf. PTFE	PTFE
• 8	1	«O» Ring stem «O» Ring spindel	Joint torique Torica eje	VITON	VITON
•• 9	1	Ball Kugel	Sphère Espera	S.S. 316	S.S. 316
• 10	2	Seats Sitzring	Sièges Asientos	Reinf. PTFE "S"	PTFE
• 11	2	Body seal Gehäusedichtung	Joint de corps Junta cuerpo	VITON	PTFE
12	1	Body Gehäuse	Corps Cuerpo	ASTM A105	A182 F316
13	2	End connections Anschlußstutzen	Embout Terminales	ASTM A105	A182 F316L
14	1	Stop-pin Anschlag	Butée Tope	S.S. 304	S.S. 304
16	4	Bolts Gehäuseschraube	Vis Goujon	ASTM A193 B7 Galvanized	ASTM A193 B8
••17	1	Stop washer Sicherungsscheiße	Rondelle-frein Arandela de seguridad	S.S. 304	S.S. 304
• 18	2	Body seal Gehäusedichtung	Joint de corps Junta de cuerpo	Free Asbestos NA35	Free Asbestos NA35
19	4	Nuts Mutter	Ecrous Tuerca	ASTM A194-2H Galvanized	ASTM A194-GR.8

BSP Parallel: BS21 Rp - ISO 228/1 - ISO 7/1Rp
 BSP Taper: BS21 Rc - ISO 7/1Rc - DIN 2999/1
 NPT: ANSI B1 20.1

S.W.: ANSI B16.11- BS 5351
 Instruction for welding the valve on the line:
 With the valve in open position tack-weld in four points on both ends. Lift-out the center piece and complete the welding. Insert the center piece and control for easy operation.

B.W.-P.E.: ANSI B16.25 Sch. 5S-10S-40-80-XS
 Note: other overall lengths are available on request.
 Instruction for welding the valve on the line: with the valve in open position tack-weld in four points on both ends. Lift-out the center piece and complete the welding. Insert the center piece and control for easy operation.

WELDED NIPPLES: ANSI B36.10 B.W. - P.E. SCH. 40-80-XS
 Note: other overall lengths are available on request.
 Instruction for welding the valve on the line: with the valve in open position tack-weld in four points on both ends and then complete the welding without desmantling the valve.

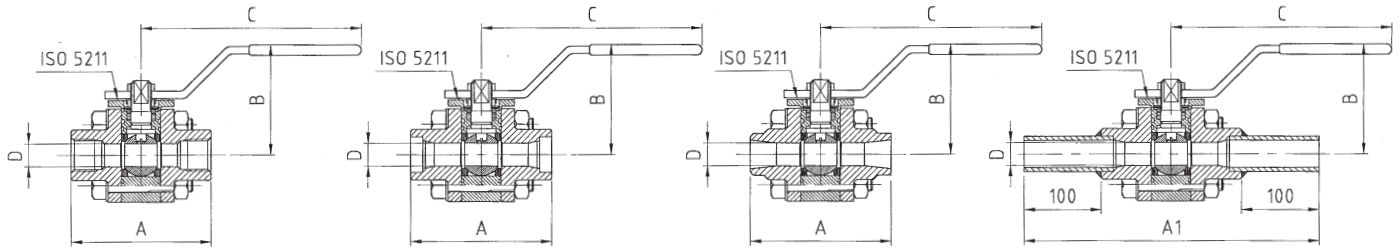

		FULL BORE					WEIGHT kg/Lbs	ISO 5211
VALVE SIZE		DIMENSIONS mm / Inch						
DN	Inch	A	A1	B	C	D		
8	1/4"	75	275	67	152	11.1	1.1	F03
		2.95	10.8	2.63	6	0.44	2.4	
10	3/8"	75	275	67	152	11.1	1	F03
		2.95	10.8	2.63	6	0.44	2.2	
15	1/2"	80	280	70	152	14.2	1.3	F03
		3.15	11	2.75	6	0.56	2.8	
20	3/4"	100	300	80	193	21	2.3	F04
		3.94	11.8	3.15	7.5	0.83	5	

		REDUCED BORE					WEIGHT kg/Lbs	ISO 5211
VALVE SIZE		DIMENSIONS mm / Inch						
DN	Inch	A	A1	B	C	D		
15	1/2"	75	275	67	152	11.1	1	F03
		2.95	10.8	2.63	6	0.44	2.2	
20	3/4"	80	280	70	152	14.2	1.3	F03
		3.15	11	2.75	6	0.56	2.8	
25	1"	100	300	80	193	21	2.3	F04
		3.94	11.8	3.15	7.5	0.83	5	

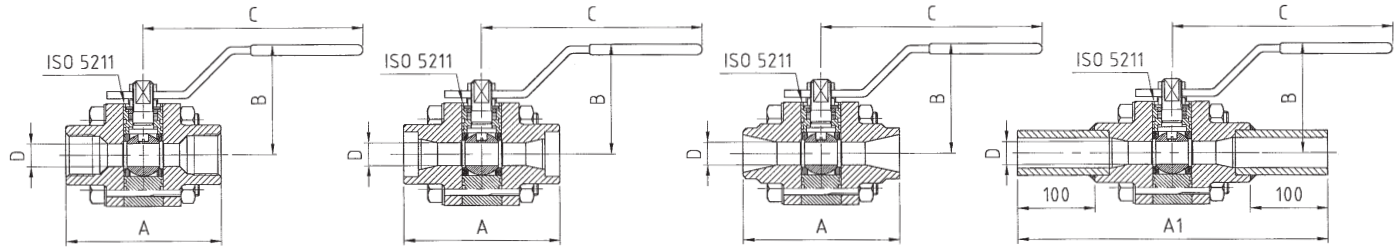

		FULL BORE					WEIGHT kg/Lbs	ISO 5211
VALVE SIZE		DIMENSIONS mm / Inch						
DN	Inch	A	A1	B	C	D		
25	1"	110	310	92	193	25.4	3.2	F04
		4.33	12.2	3.62	7.5	1	7	
32	1 1/4"	120	320	108	225	31.7	4.3	F05
		4.72	12.6	4.25	9	1.25	9.5	
40	1 1/2"	140	340	113	225	38	5.8	F05
		5.51	13.4	4.45	9	1.5	12.8	

		REDUCED BORE					WEIGHT kg/Lbs	ISO 5211
VALVE SIZE		DIMENSIONS mm / Inch						
DN	Inch	A	A1	B	C	D		
32	1 1/4"	110	310	92	193	25.4	3.1	F04
		4.33	12.2	3.62	7.5	1	6.8	
40	1 1/2"	120	320	108	225	31.7	4.2	F05
		4.72	12.6	4.25	9	1.25	9.2	
50	2"	140	340	113	225	38	5.5	F05
		5.51	13.4	4.45	9	1.5	12.1	

DIFFERENT CONFIGURATIONS

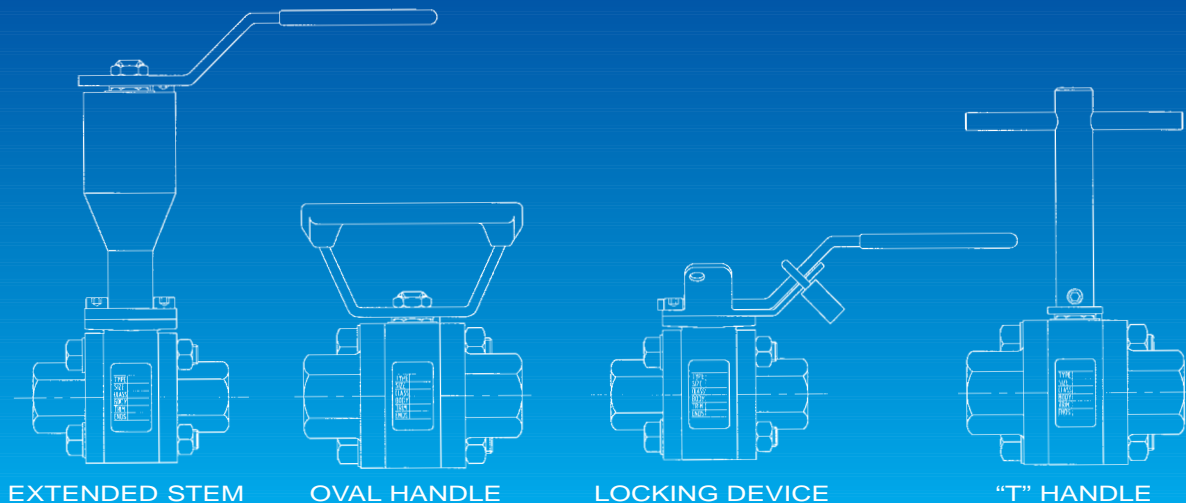

EXTENDED STEM

OVAL HANDLE

LOCKING DEVICE

"T" HANDLE

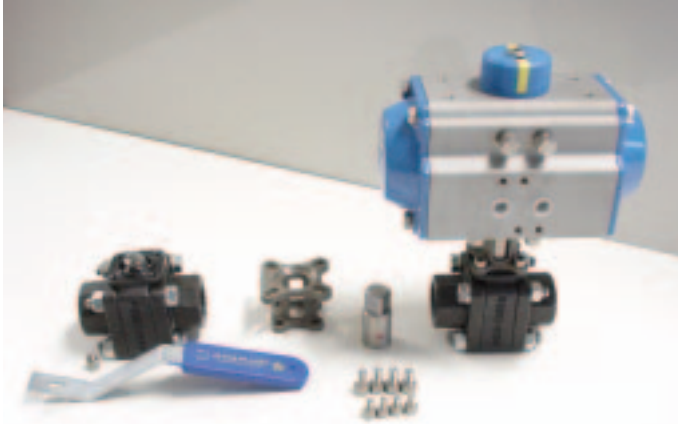

HOW TO TRANSFORM A MANUAL OPERATED VALVE IN AUTOMATED VALVES

- 1) Take out the handle nut
- 2) Take out the handle
- 3) For sizes: 1/4" - 3/8" - 1/2" F.B. or 1/2" - 3/4" R.B. handle nut is not to be fitted
For bigger sizes the handle nut has to be fitted

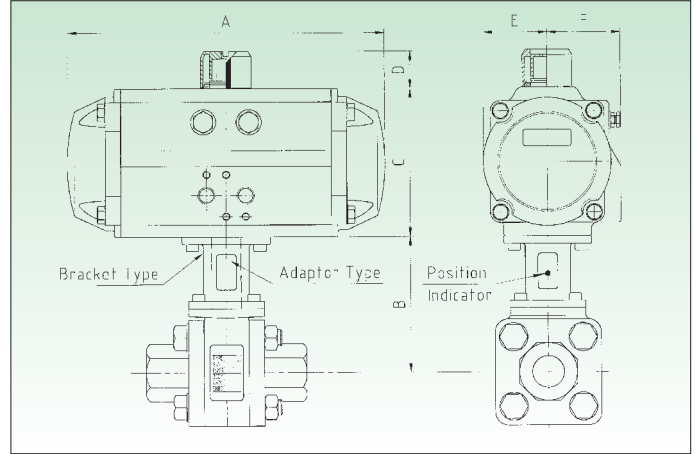
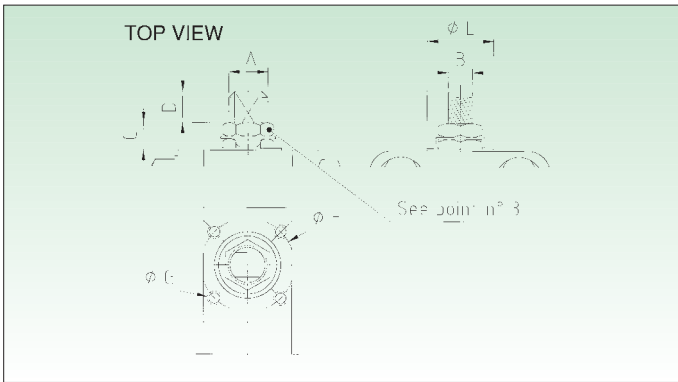

THE BELOW TABLE REFERS TO AIR TORQUE ACTUATORS

VALVE SIZE				DOUBLE ACTING ACTUATOR								
FULL BORE		RED. BORE		DIMENSIONS (mm)						ACTUATOR TYPE	BRACKET TYPE	ADAPTOR TYPE
Inch	DN	Inch	DN	A	B	C	D	E	F			
1/4"	8	-	-	140.5	65	69	20	29	41.5	AT 051 DA ISO F04-CH11	ST1	A1/E
3/8"	10	1/2"	15	140.5	65	69	20	29	41.5	AT 051 DA ISO F04-CH11	ST1	A1/E
1/2"	15	3/4"	20	158.5	67	85	20	36	47	AT 101 DA ISO F05-CH14	ST1	A1/A
3/4"	20	1"	25	158.5	73	85	20	36	47	AT 101 DA ISO F05-CH14	ST2	A2/A
1"	25	1.1/4"	32	210.5	73	102	20	42.5	52	AT 201 DA ISO F05/F07-CH14	ST2	A2/B
1.1/4"	32	1.1/2"	40	210.5	82	102	20	42.5	52	AT 201 DA ISO F05/F07-CH14	ST3	A3/E
1.1/2"	40	2"	50	210.5	86	102	20	42.5	52	AT 201 DA ISO F05/F07-CH14	ST3	A3/E

VALVE SIZE				SPRING RETURN ACTUATOR								
FULL BORE		RED. BORE		DIMENSIONS (mm)						ACTUATOR TYPE	BRACKET TYPE	ADAPTOR TYPE
Inch	DN	Inch	DN	A	B	C	D	E	F			
1/4"	8	-	-	158.5	65	85	20	36	47	AT 101 S10 ISO F05-CH14	ST1	A1/A
3/8"	10	1/2"	15	158.5	65	85	20	36	47	AT 101 S10 ISO F05-CH14	ST1	A1/A
1/2"	15	3/4"	20	210.5	67	102	20	42.5	52	AT 201 S10 ISO F05/F07-CH14	ST1	A1/A
3/4"	20	1"	25	210.5	73	102	20	42.5	52	AT 201 S10 ISO F05/F07-CH14	ST2	A2/A
1"	25	1.1/4"	32	247.5	73	115	20	49.5	56.8	AT 251 S10 ISO F05/F07-CH17	ST2	A2/E
1.1/4"	32	1.1/2"	40	268.5	82	127	20	56	67	AT 301 S10 ISO F05/F07-CH17	ST3	A3/A
1.1/2"	40	2"	50	268.5	86	127	20	56	67	AT 301 S10 ISO F05/F07-CH17	ST3	A3/A

DIMENSIONS AND TORQUE TO SELECT ACTUATOR SUITABLE FOR STARLINE BALL VALVES

VALVE SIZE				DIMENSIONS							ISO 5211	BREAK AWAY TORQUE N.m
FULL BORE		RED. BORE		A	B	C	D	ØE	ØF	ØG		
Inch	DN	Inch	DN	mm	mm	mm	mm	mm	mm	mm		
1/4"	8	-	-	M10x1	5.5	5.4	3.6	25	36	M5x8	F03	9
3/8"	10	1/2"	15	M10x1	5.5	5.4	3.6	25	36	M5x8	F03	9
1/2"	15	3/4"	20	M10x1	5.5	6	3.6	25	36	M5x8	F03	12
3/4"	20	1"	25	M12x1.25	7.5	5	9	30	42	M5x8	F04	18
1"	25	1.1/4"	32	M12x1.25	7.5	10	10	30	42	M5x8	F04	25
1.1/4"	32	1.1/2"	40	M15x1.5	8.9	14	13	35	50	M6x10	F05	30
1.1/2"	40	2"	50	M15x1.5	8.9	14	14	35	50	M6x10	F05	35

*BREAK AWAY TORQUE AT MAX. WORKING PRESSURE WITH SEATS TYPE PTFE + 25% C. GRAPHITE 'S' FOR SEATS IN VIRGIN PTFE 'T' -5%.
CONVERSION FACTORS: 1Nm= 0,7376 Lb-in / 1 lb.ft.= 1.365 Nm / 1 Nm= 8,86 Lb-in

General Remarks:

- 1) The above actuators have been selected considering an air supply of 80 psi or 5,6 bar.
- 2) On spring return actuators teh N. of spring per side is 5.
- 3) For different air supply please see Air Torque Catalogue.
- 4) Bracket and adaptor are dimensioned to fit Air Torque actuators.
- 5) When air supply for actuator is lower than 5,6 bar bigger actuator must be selected and bracket plus adaptor become special

It must be understood that many factor can influence the torque of ball valves in field service. For this reason to SELECT PROPER ACTUATOR it must be used the "TORQUE ADJUSTMENT FACTORS" table no. A003/94.

NET BREAK AWAY TORQUE OF VALVES + PROCESS MEDIA + FREQUENCE OF OPERATION + PROCESS TEMPERATURE + VALVE SEATING MATERIAL + SUGGESTED SAFETY FACTOR = TORQUE TO SELECT ACTUATOR OR GEAR IN NM

"STARLINE" BRACKETS ISO 5211 IN STAINLESS STEEL

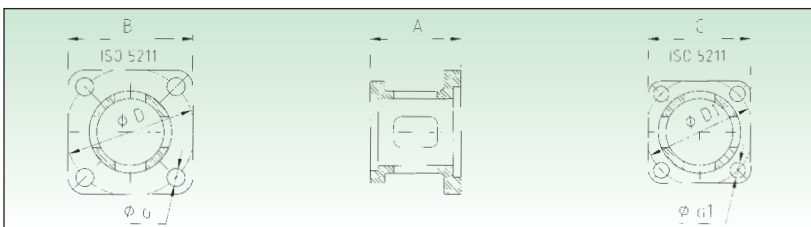

TYPE OF BRACKET	DIMENSIONS (mm)							ISO 5211
	A	B	C	D	D1	d	d1	
ST1	35	48.5	36.5	42-50	36	6-7	6	F03/F04-F05
ST2	35	48.5	40	50	42	7	6	F04/F05
ST3	39	48.5	48.5	50	50	7	7	F05/F05
ST35	45	65.5	48.5	70	50	9	7	F05/F07
ST4	45	65.5	65.5	70	70	9	9	F07/F07
ST5	56	92	92	102	102	11	11	F10/F10

DESCRIPTION

- CONSTRUCTION** : THREE PIECES BOLTED CONSTRUCTION - SOLID BALL - ANTI BLOW OUT PROOF STEM DESIGN
SOFT SEATS - ANTISTATIC DEVICE - ISO 5211 ON THE TOP FOR EASY AUTOMATION.
- SIZE** : DN 8 ÷ 40 FULL BORE -- DN 15 ÷ 50 REDUCED BORE
1/4" ÷ 1.1/2" FULL BORE -- 1/2" ÷ 2" REDUCED BORE
- CLASS** : PN 16 ÷ 100 or ASME 150 ÷ 800 LBS or 1000 ÷ 2000 WOG
- TEMPERATURE** : -100°C UP TO + 260°C
- MATERIAL** : ASTM A105 - 316 - 316L
- DESIGN** : ASME B16.34 - ASME B31.1 - BS5351 - P.E.D. 97/23/EC - ATEX 94/9 CE
- MARKING** : MSS SP25
- CE 0038** : ACCORDING TO DIRECTIVE 97/23/CE - MODULE H CATEGORY III - NOTIFIED BODY LLOYD'S REGISTERED
CERTIFICATE NR. RPS 01060304/01
- Ex IM2/II 2GD** : ACCORDING TO ATEX 94/9 CE - TECHNICAL FILE NR. ST01 ATEX
- TEST CERTIFICATE** : UNI EN 10204 TYPE 3.1B UNLESS OTHERWISE REQUIRED
- SERVICES** : FOR GENERAL SERVICES AND CHEMICAL INDUSTRIES

PRESSURE/TEMPERATURE LIMITATIONS OF SEAT SEAL

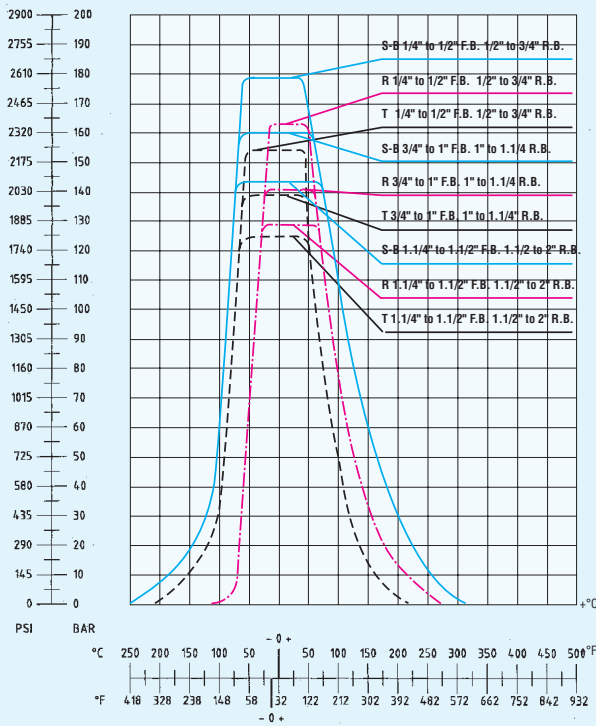

MAXIMUM WORKING PRESSURE (WOG/CWP)

VALVE SIZE	FULL BORE		1/4"	3/8"	1/2"	3/4"	1"	1.1/4"	1.1/2"	
	REDUCED BORE									
SEAT MATERIAL	Reinforced PTFE (S-B)		Psi	2580	2580	2580	2320	2320	2060	2060
	Reinforced PTFE (R)		Bar	178	178	178	160	160	142	142
	Virgin PTFE (T)		Psi	2350	2350	2350	2030	2030	1860	1860
			Bar	162	162	162	140	140	128	128
			Psi	2250	2250	2250	2000	2000	1800	1800
			Bar	155	155	155	138	138	124	124

CLASS RATING

VALVE SIZE	FULL BORE		1/4"	3/8"	1/2"	3/4"	1"	1.1/4"	1.1/2"		
	REDUCED BORE			1/2"	3/4"	1"	1.1/4"	1.1/2"	2"		
SEAT MATERIAL	Reinforced PTFE (S-B)		150 ÷ 800								
	Reinforced PTFE (R)		150 ÷ 800				150 ÷ 600				
	Virgin PTFE (T)		150 ÷ 800				150 ÷ 600				

SEAT MATERIALS

- "T" = PTFE Virgin
- "R" = PTFE + 15% Fiberglass
- "S" = PTFE + 20% C. 5% Graphite
- "B" = PTFE +60% Bronze

FLOW DATA

The following flow rates were determined for ball valves in fully open position and a water temperature of 60°F (15°C).
Kv value is the full capacity flow rate through the ball valve in cubic metres per hour (m³/h) with a pressure drop of 1 bar.
Cv value is the full capacity flow rate through the ball valve in gallons/min. of water at 60°F with a pressure drop of 1 psi.

REDUCED BORE

VALVE SIZE	1/2"	3/4"	1"	1.1/4"	1.1/2"	2"
Cv	8	13	32	48	82	120
KV	6,8	11	27,5	41	70	103

FULL BORE

VALVE SIZE	1/4"	3/8"	1/2"	3/4"	1"	1.1/4"	1.1/2"
Cv	8	8	12	30	45	78	115
KV	6,8	6,8	10	26	38	67	99

SALES ORGANIZATION



MAIN DISTRIBUTORS

**Norway, Sweden, Denmark, Netherlands,
Belgium, Switzerland, Austria, Greece,
Brasil, Usa, Canada, Australia, New Zeland, South Africa,
UAE, Czech Republic, Slovakia, Poland
Singapore, Romania, Oman, Saudi Arabia, Kuwait**

STARLINE S.p.A.

Via F. Baracca, 30 - 24060 S. PAOLO D'ARGON (Bergamo) ITALY
Phone: 0039 035/958041/958102 - Fax: 0039 035/958413
<http://www.starline.it> - e-mail: starline@starline.it

STARLINE BALL VALVES LTD
Telford Way Stephenson Ind. Est.
Coalville Leicestershire LE 67 3HE
Great Britain
Phone: 0044 (0)1530815818
Fax: 0044 (0)1530815819
<http://www.acvalvealliance.com>
e-mail: Starline@acvalvealliance.com

STARLINE FRANCE
7, Parc d'Activités
de la Verdrière 1
13880 VELAUX - France
Phone: 0033 (0)442878400
Fax: 0033 (0)442878404
<http://www.star-line.fr>
e-mail: infos@star-line.fr

STARLINE IBERICA S.A.
Poligono Industrial El Circuit
C/Rec Del Molinar F-3
08160 Montmelò Barcelona - Spain
Phone: 0034 (0)935799370
Fax: 0034 (0)935799244
<http://www.starline.es>
e-mail: starline@starline.es

STARLINE VALVES OY
Martinkyläntie, 39
01720 Vantaa - Finland
Phone: 0035 (0)898787711
Fax: 0035 (0)898787221
<http://www.starline.fi>
e-mail: starline@starline.fi

STARLINE Armaturen GmbH
Industriestrasse, 25
64569 Nauheim - Germany
Phone: 0049 (0)6152987655
Fax: 0049 (0)6152987656
e-mail: starline.gmbh@t-online.de

Your Representative:

FLUIDTECHNIK®
bohemia

FLUIDTECHNIK BOHEMIA, s.r.o.

Olomoucká 87, CZ-627 00 Brno
• tel.: +420 548 426 811
• e-mail: brno@fluidtechnik.eu
• www.fluidtechnik.eu