

Globe Valve Metal

Construction

The GEMÜ 530 pneumatically operated 2/2-way globe valve has a robust low maintenance stainless steel piston actuator.

The valve spindle is sealed by a self-adjusting gland packing providing low maintenance and reliable valve spindle sealing even after a long service life. The wiper ring fitted in front of the gland packing protects it against contamination and damage.

Features

- Suitable for inert and corrosive* liquid and gaseous media
- Valve bodies available in SG iron and stainless steel
- Flanged versions
- Customized control valve versions available
- Free from non-ferrous metals
- Versions according to ATEX on request

Advantages

- Stainless steel actuator for simple cleanability, corrosive atmospheres
- Good flow capability and compact design
- Optical position indicator is standard for NC control function (optional for NO and DA control functions).
- Accessories:
 - Electrical position indicators
 - Combi switchboxes
 - Electro-pneumatic positioners/process controllers (see data sheet GEMÜ 530 control valve)
 - Stroke limiter
- Standard gland packing suitable for vacuum up to 20 mbar (abs.)

*see information on working medium on page 2



Sectional drawing

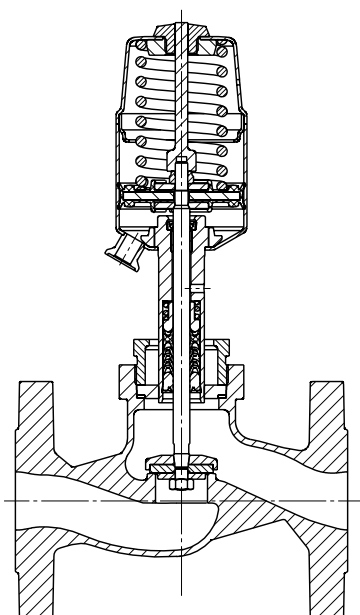

Technical data

Working medium

Corrosive, inert, gaseous and liquid media and steam which have no negative impact on the physical and chemical properties of the body and seal material.

Medium temperature -10 °C to 180 °C

Operating pressure see table below

Max. permissible viscosity 600 mm²/s (cSt)

Other versions for lower/higher temperatures on request

Control medium

Inert gases

Max. perm. temperature of control medium: 60 °C

Filling volume:

Actuator size 1G1, 1M1: 0.025 dm³

Actuator size 2G1, 2M1: 0.084 dm³

Actuator size 3G1, 3M1: 0.245 dm³

Actuator size 4G1: 0.437 dm³

Actuator size 5G1: 0.798 dm³

Actuator size 6G: 2.150 dm³

Ambient conditions

Max. ambient temperature 60 °C

Maximum permissible seat leakage rate

Seat seal	Standard	Test procedure	Leakage rate	Test medium
PTFE	DIN EN 12266-1	P12	A	air
Metal	DIN EN 12266-1	P12	F	air

Control pressure [bar]

C. f. 1 Normally closed (NC) / Flow direction: under the seat

Actuator size	Control pressure [bar]
1G1, 2G1, 3G1, 4G1	4.0 - 8.0
5G1	5.0 - 8.0
6G4	3.5 - 8.0
6G5	4.5 - 8.0
6G6	5.0 - 8.0

C. f. 1 Normally closed (NC) / Flow direction: over the seat

1M1, 2M1, 3M1	max. 7 bar
---------------	------------

Higher control pressures on request.

C. f. 2 Normally open (NO) / C. f. 3 Double acting (DA) / Flow direction: under the seat

for values see diagram see page 5

Technical data

Max. operating pressure [bar]

Actuator size	DN 15	DN 20	DN 25	DN 32	DN 40	DN 50	DN 65	DN 80	DN 100
C. f. 1 Normally closed (NC) / Flow direction: under the seat									
1G1	10.0	6.0	-	-	-	-	-	-	-
2G1	22.0	12.0	7.0	4.0	-	-	-	-	-
3G1	-	25.0	16.0	10.0	6.0	3.0	-	-	-
4G1	-	-	25.0	18.0	12.0	7.0	-	-	-
5G1	-	-	40.0	35.0	20.0	15.0	8.0	6.0	3.0
6G4	-	-	-	-	-	-	16.0	-	-
6G5	-	-	-	-	-	40.0	-	-	-
6G6	-	-	-	-	-	-	-	16.0	12.0
C. f. 1 Normally closed (NC) / Flow direction: over the seat									
1M1	10.0	10.0	-	-	-	-	-	-	-
2M1	10.0	10.0	10.0	-	-	-	-	-	-
3M1	-	10.0	10.0	10.0	10.0	10.0	-	-	-
C. f. 2 Normally open (NO) / C. f. 3 Double acting (DA) / Flow direction: under the seat									
1G	28.0	17.0	11.0	-	-	-	-	-	-
2G	40.0	40.0	25.0	16.0	9.0	-	-	-	-
3G	-	40.0	40.0	30.0	20.0	12.0	-	-	-
4G	-	-	-	40.0	30.0	20.0	-	-	-
5G	-	-	-	40.0	40.0	32.0	19.0	15.0	10.0

For max. operating pressures the pressure/temperature correlation must be observed (see table on page 4). All pressures are gauge pressures. When the flow is over the plug (M), there may be the danger of water hammer with liquid media!

Technical data

Kv values [m³/h]

Nominal size	DN 15	DN 20	DN 25	DN 32	DN 40	DN 50	DN 65	DN 80	DN 100
	4.6	8.0	13.0	22.0	35.0	50.0	90.0	127.0	200.0

Kv values determined acc. to DIN EN 60534. The Kv value data refers to control function 1 (NC) and the largest actuator for each nominal size. The Kv values for other product configurations (e.g. other connections or body materials) may differ.

Pressure / temperature correlation for globe valve bodies

Connection code	Material code	Max. allowable operating pressures in bar at temperature °C*					
		RT	100	150	200	250	300
8	37	16.0	16.0	14.5	13.4	12.7	11.8
10	37	25.0	25.0	22.7	21.0	19.8	18.5
11	37	40.0	40.0	36.3	33.7	31.8	29.7
39	37	19.0	16.0	14.8	13.6	12.0	10.2
8	90	16.0	16.0	15.5	14.7	13.9	11.2
39	90	17.0	16.0	14.8	13.9	12.1	10.2

* The valves can be used down to -10°C RT = Room Temperature All pressures are gauge pressures.
Pressure/temperature correlation for connection code 48: DN 15 - 40 see connection code 10, DN 50 see connection code 8.

Operating pressure / Control pressure characteristics
Control function 1: normally closed (NC) / Flow direction: over the seat

Actuator size 2M1

min. control pressure dependent on operating pressure

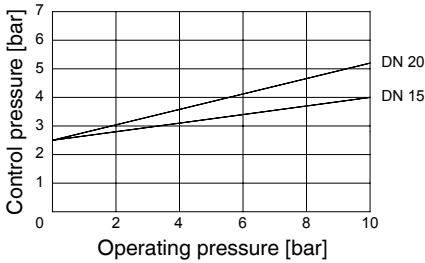

Actuator size 1M1

min. control pressure dependent on operating pressure

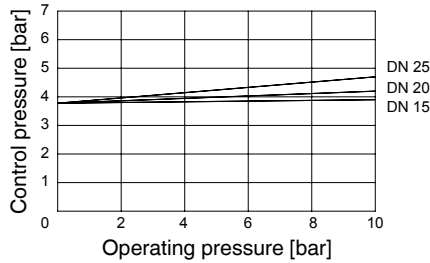

Actuator size 3M1

min. control pressure dependent on operating pressure

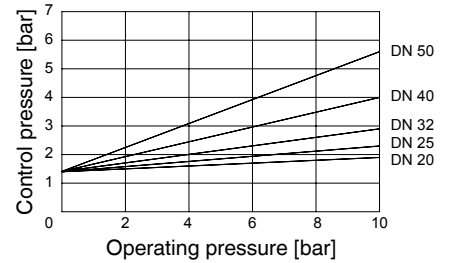

Operating pressure / Control pressure characteristics
Control function 2: normally open (NO) / Control function 3: double acting (DA)
Flow direction: under the seat

Actuator size 1G1

min. control pressure dependent on operating pressure

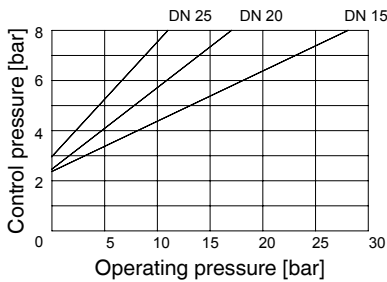

Actuator size 2G1

min. control pressure dependent on operating pressure

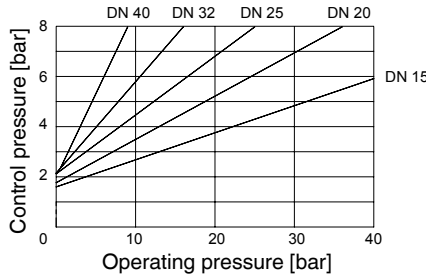

Actuator size 3G1

min. control pressure dependent on operating pressure

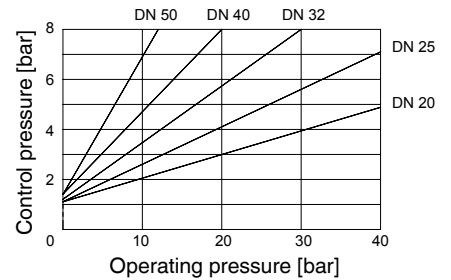

Actuator size 4G1

min. control pressure dependent on operating pressure

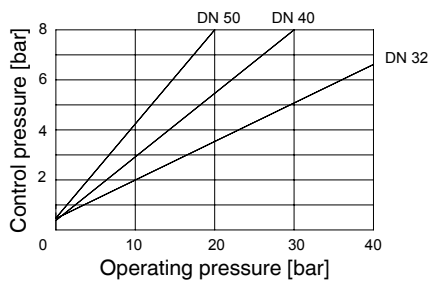

Actuator size 5G1

min. control pressure dependent on operating pressure

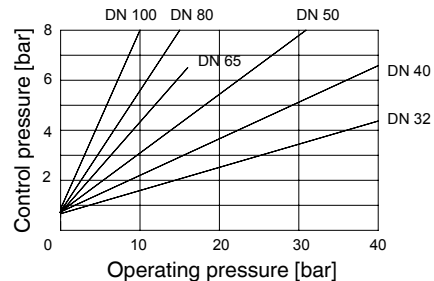

Order data

Body configuration	Code
2/2-way body	D

Connection	Code
Flanges Flanges EN 1092 / PN16 / form B, length EN 558, series 1, ISO 5752, basic series 1	8
Flanges EN 1092 / PN25 / form B, length EN 558, series 1 ISO 5752, basic series 1	10
Flanges EN 1092 / PN40 / form B, length EN 558, series 1 ISO 5752, basic series 1	11
Flanges ANSI Class 150 RF, face-to-face dimension FTF EN 558 series 1, ISO 5752, basic series 1	39
Flanges drilled according to JIS 20K (DN 15 - 40), Flanges drilled according to JIS 10K (DN 50), length EN 558, series 10, ASME/ANSI B 16.10 table 1, column 16	48

Valve body material	Code
1.4408, Investment casting	37
EN-GJS-400-18-LT (GGG 40.3) SG iron	90

Seat seal	Code
PTFE	5
PTFE, glass fibre reinforced	5G

Control function	Code
Normally closed (NC)	1
Normally open (NO)	2*
Double acting (DA)	3*

* actuator size 1 - 5

Actuator size	Code
Actuator 1 piston ø 42 mm	1
Actuator 2 piston ø 60 mm	2
Actuator 3 piston ø 80 mm	3
Actuator 4 piston ø 100 mm	4
Actuator 5 piston ø 130 mm	5
Actuator 6 piston ø 234 mm	6*

* Valve body material 37, Control function 1,
Flow direction: under the seat

Flow direction	Code
Flow under the seat	G*
Flow over the seat	M**

** only control function NC

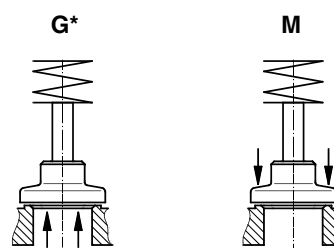

* Preferred flow direction with incompressible liquid media
to avoid "water hammer"

Spring set	Code
Standard Actuator 1 - 5	1
Standard Actuator 6	3 - 6

Version	Code
Media temperature -10 to 210 °C	2023*

* with actuator size 1 - 5

Order data

Special version

Code

Special version for oxygen (max. temperature 60 °C, max. operating pressure 10 bar),
Flow direction: under the seat

S

Order example	530	25	D	11	37	5	1	2	G	1	-	S
Type	530											
Nominal size		25										
Body configuration (code)			D									
Connection (code)				11								
Valve body material (code)					37							
Seat seal (code)						5						
Control function (code)							1					
Actuator size (code)								2				
Flow direction (code)									G			
Spring set (code)										1		
Version (code)											-	
Special version (code)												S

Version for food contact

For food contact, the product must be ordered with the following ordering options:

Seat seal code 5, 5G

Valve body material code 37

Actuator dimensions / Installation dimensions [mm]

Actuator dimensions

Actuator size	øB	M	A4 max*	G
1	46	M16x1	12	G 1/8
2	63	M16x1	22	G 1/8
3	84	M16x1	28	G 1/4
4	104	M22x1.5	32	G 1/4
5	135	M22x1.5	41	G 1/4
6	240	M26x1.5	40	G 1/4

* dependent on nominal sizes

Installation dimensions / weight of valve, connection code 8, 10, 39, 48

DN	SW1 metric	Actuator size 1 ø 42 mm		Actuator size 2 ø 60 mm		Actuator size 3 ø 80 mm		Actuator size 4 ø 100 mm		Actuator size 5 ø 130 mm		Actuator size 6 ø 234 mm	
		CT	Weight [kg]	CT	Weight [kg]	CT	Weight [kg]	CT	Weight [kg]	CT	Weight [kg]	CT	Weight [kg]
15	36	167	3.1	213	3.2	-	-	-	-	-	-	-	-
20	41	174	3.8	220	4.0	-	-	-	-	-	-	-	-
25	46	-	-	231	4.8	247	5.5	285	6.9	-	-	-	-
32	55	-	-	236	6.6	252	7.3	290	8.7	317	11.8	-	-
40	60	-	-	-	-	263	8.4	301	9.8	328	12.9	-	-
50	55	-	-	-	-	271	10.7	309	12.1	336	15.2	-	-
65	75	-	-	-	-	-	-	-	-	359	20.4	375	35.0
80	75	-	-	-	-	-	-	-	-	379	23.1	387	41.0
100	75	-	-	-	-	-	-	-	-	400	29.0	408	48.0

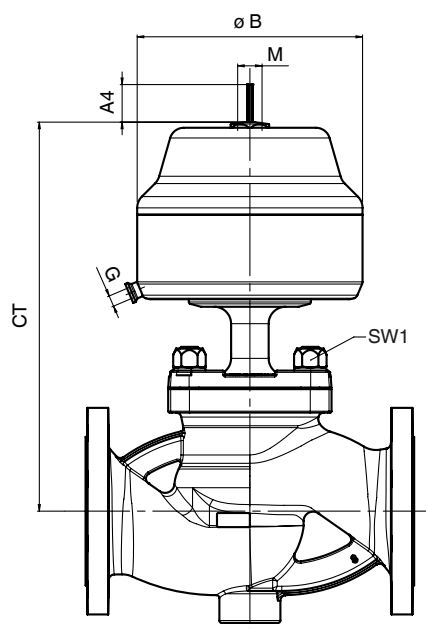
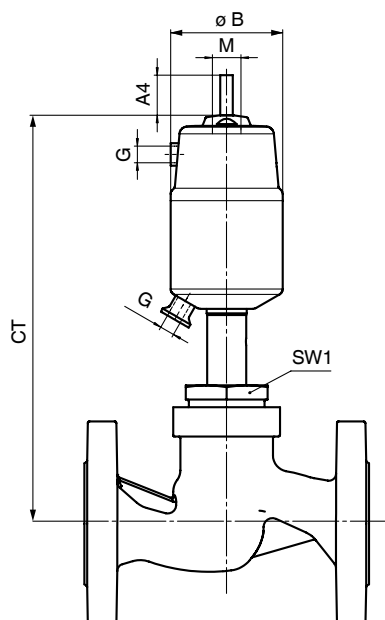

Actuator dimensions / Installation dimensions [mm]

Installation dimensions / weight of valve, connection code 11

DN	SW1 metric	Actuator size 1 ø 42 mm		Actuator size 2 ø 60 mm		Actuator size 3 ø 80 mm		Actuator size 4 ø 100 mm		Actuator size 5 ø 130 mm		Actuator size 6 ø 234 mm	
		CT	Weight [kg]	CT	Weight [kg]	CT	Weight [kg]	CT	Weight [kg]	CT	Weight [kg]	CT	Weight [kg]
15	36	167	3.1	213	3.2	-	-	-	-	-	-	-	-
20	41	174	3.8	220	4.0	-	-	-	-	-	-	-	-
25	46	-	-	231	4.8	247	5.5	285	6.9	-	-	-	-
32	55	-	-	236	6.6	252	7.3	290	8.7	317	11.8	-	-
40	60	-	-	-	-	263	8.4	301	9.8	328	12.9	-	-
50	55	-	-	-	-	283	10.7	321	12.1	348	15.2	362	34.0

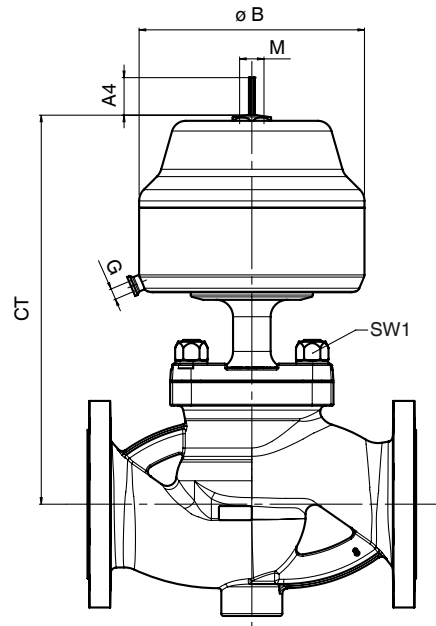
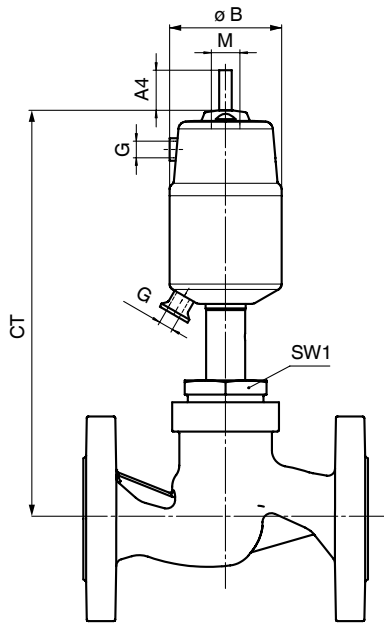

Body dimensions [mm]

Flanges, connection code 8 Valve body material 1.4408 (code 37), EN-GJS-400-18-LT (code 90)

DN	Material code 37					Material code 90					Weight [kg]
	Number of bolts	FTF	ø D	ø K	ø L	Number of bolts	FTF	ø D	ø K	ø L	
15	-	-	-	-	-	4	130	95	65	14	2.2
20	-	-	-	-	-	4	150	105	75	14	3.0
25	-	-	-	-	-	4	160	115	85	14	3.7
32	-	-	-	-	-	4	180	140	100	18	5.3
40	-	-	-	-	-	4	200	150	110	18	6.3
50	4	230	165	125	18	4	230	165	125	18	8.4
65	4	290	185	145	18	4	290	185	145	18	12.7
80	8	310	200	160	18	8	310	200	160	18	15.4
100	8	350	220	180	18	8	350	220	180	18	23.0

For materials see overview on page 9

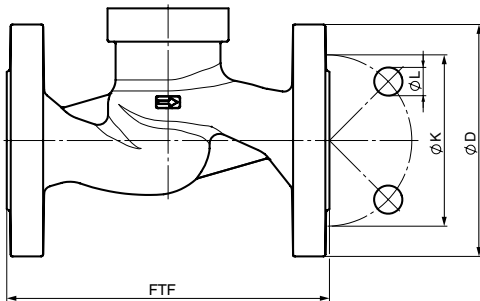

DN 15 - 50

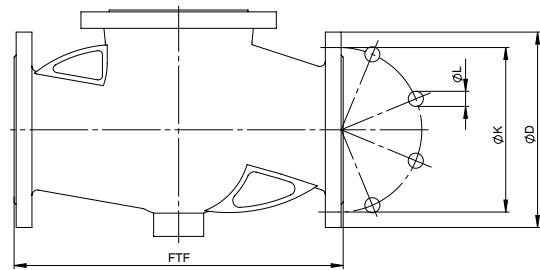

65 - 100

Flanges, connection code 10, 11, 48 Valve body material 1.4408 (code 37)

DN	Number of bolts	Connection code 10				Connection code 11				Connection code 48				Weight [kg]
		FTF	ø D	ø K	ø L	FTF	ø D	ø K	ø L	FTF	ø D	ø K	ø L	
15	4	-	-	-	-	130	95	65	14	108	95	70	15	2.2
20	4	-	-	-	-	150	105	75	14	117	100	75	15	3.0
25	4	-	-	-	-	160	115	85	14	127	125	90	19	3.7
32	4	180	140	100	18	180	140	100	18	-	-	-	-	5.3
40	4	200	150	110	18	200	150	110	18	165	140	105	19	6.3
50	4	-	-	-	-	230	165	125	18	203	155	120	19	8.4

For materials see overview on page 9

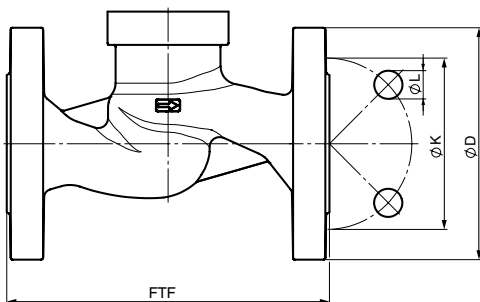

DN 15 - 50 code 48
DN 15 - 40 code 11

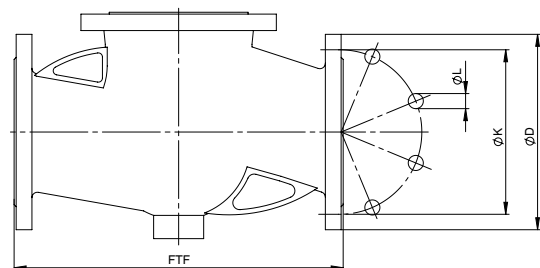

DN 50 code 11

Body dimensions [mm]

Flanges, connection code 39 Valve body material 1.4408 (code 37), EN-GJS-400-18-LT (code 90)

DN	Number of bolts	FTF	ø D	ø K	ø L	Weight [kg]
15	4	130	90	60.3	15.9	2.2
20	4	150	100	69.9	15.9	3.0
25	4	160	110	79.4	15.9	3.7
32	4	180	115	88.9	15.9	5.3
40	4	200	125	98.4	15.9	6.3
50	4	230	150	120.7	19.0	8.4
65	4	290	180	139.7	19.0	12.7
80	4	310	190	152.4	19.0	15.4
100	8	350	230	190.5	19.0	23.0

For materials see overview on page 9

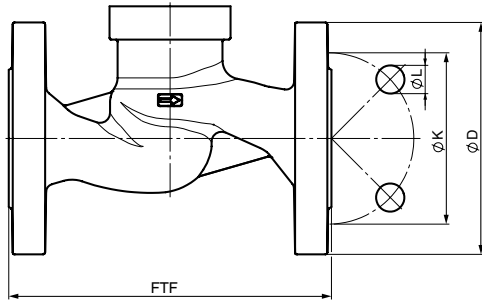

DN 15 - 50

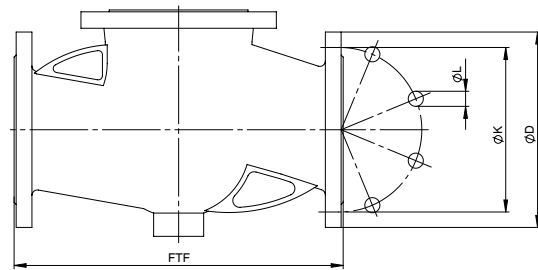

DN 65 - 100

Overview of metal bodies for GEMÜ 530

Connection code	8		10	11	39		48
	37	90	37	37	37	90	37
DN 15	-	X	-	X	X	X	X
DN 20	-	X	-	X	X	X	X
DN 25	-	X	-	X	X	X	X
DN 32	-	X	X	X	X	X	-
DN 40	-	X	X	X	X	X	X
DN 50	X	X	-	X	X	X	X
DN 65	X	X	-	-	X	X	-
DN 80	X	X	-	-	X	X	-
DN 100	X	X	-	-	X	X	-

For further globe valves, accessories and other products, please see our Product Range catalogue and Price List.
Contact GEMÜ.

GEMÜ VALVES, MEASUREMENT
AND CONTROL SYSTEMS

